



Description:
MS v M Sync chart and setting instruction for timing staggered meters

1001 Blake st. Edwardsville, KS 66111
913.438.1700 913.438.5455 (fax)

Part No.: **550078**

REV	Description	ECN	Date
A	Schematic release	E00523	11/12/2015
B	Added 90 cell info	E00914	4/2/2019

TIMING INSTRUCTIONS

1. Install the timing indicator #804060 on the meter that is being timed.
2. Turn the main hex shaft until all the slack is removed from the drive chains and the center of a disc hole is aligned with the end of the singulator on the meter without the timing sprocket.
3. Locate the required offset angle, on the chart below, base off the disc hole number and desire seed spacing.
4. Loosen the locking set screws on the timing sprocket.
5. Rotate the meter disc CCW to remove any slack while adjust the timing set screw on the timing sprocket until the back of a disc hole matches the offset angle on the indicator (CW to decrease angle & CCW to increase angle).
6. Tighten the locking set screws on the timing meter and replace the timing indicator with the original singulator.

Seed disc **Chart below displays the offset angle required based off seed spacing and disc hole number**

Seed disc holes	Seed spacing																										
	1.00	1.25	1.50	1.75	2.00	2.25	2.50	2.75	3.00	3.25	3.50	3.75	4.0	4.5	5.0	5.5	6.0	6.5	7.0	7.5	8.0	8.5	9.0	9.5	10.0	10.5	11.0
18	15	6	13	7.1	13	12	8	0.9	12	0.8	8.6	15	1.3	11	19	5.5	11	15	19	2.7	5.6	8.2	11	12.6	14.5	16.2	17.7
30	9	3.6	8	4.3	7.5	7.3	4.8	0.5	7	0.5	5.1	9.2	0.8	6.7	11	3.3	6.5	9.2	12	1.6	3.4	4.9	6.3	7.58	8.7	9.71	10.6
36	7.5	3	6.7	3.6	6.3	6.1	4	0.5	5.8	0.4	4.3	7.7	0.6	5.6	9.5	2.7	5.4	7.7	9.6	1.3	2.8	4.1	5.3	6.32	7.25	8.1	8.86
60	4.5	1.8	4	2.1	3.8	3.7	2.4	0.3	3.5	0.2	2.6	4.6	0.4	3.3	5.7	1.6	3.3	4.6	5.8	0.8	1.7	2.5	3.2	3.79	4.35	4.86	5.32
72	3.8	1.5	3.3	1.8	3.1	3.1	2	0.2	2.9	0.2	2.1	3.8	0.3	2.8	4.8	1.4	2.7	3.8	4.8	0.7	1.4	2.1	2.6	3.16	3.63	4.05	4.43
90	3	1.2	2.7	1.4	2.5	2.4	1.6	0.2	2.3	0.2	1.7	3.1	0.3	2.2	3.8	1.1	2.2	3.1	3.9	0.5	1.1	1.6	2.1	2.53	2.9	3.24	3.55
120	2.3	0.9	2	1.1	1.9	1.8	1.2	0.1	1.8	0.1	1.3	2.3	0.2	1.7	2.9	0.8	1.6	2.3	2.9	0.4	0.8	1.2	1.6	1.89	2.18	2.43	2.66

TIMEABLE METER

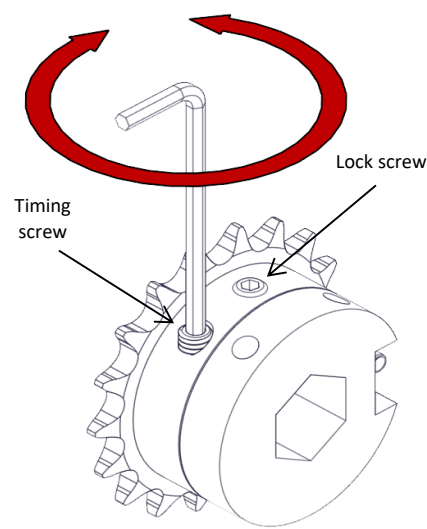
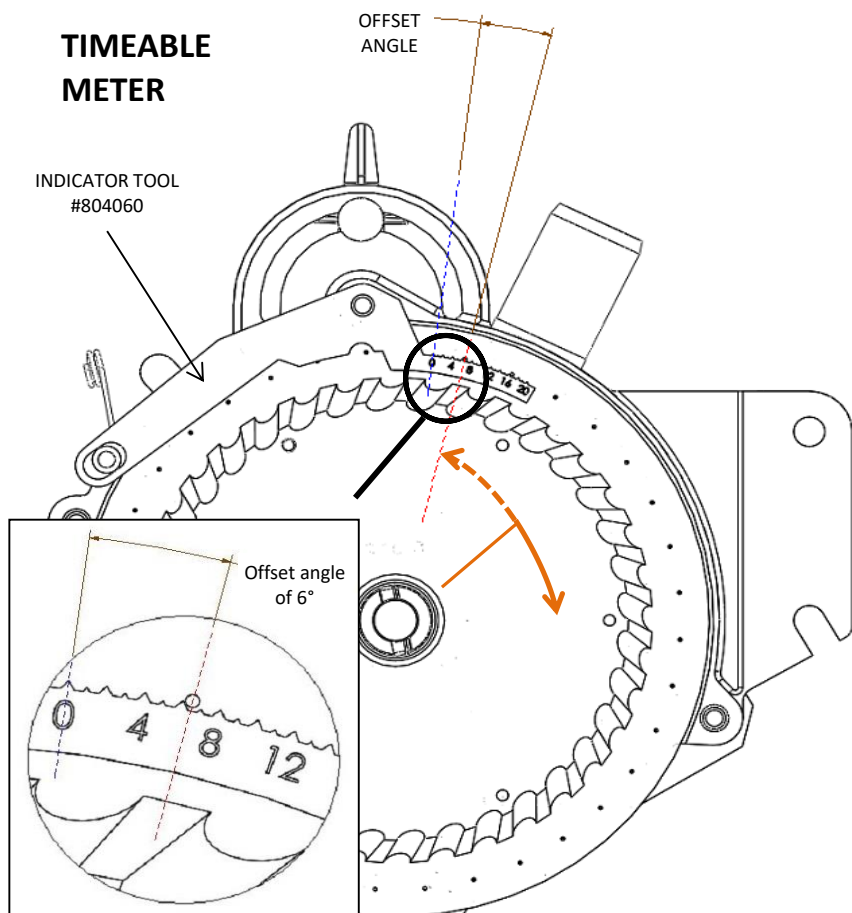

Timing sprocket # 100596