

# **MONOSEM**

Enhanced precision

## **Mounted Rigid**

# **NG plus**

## **OPERATOR & PARTS MANUAL**

### **INSTRUCTIONS**

- Safety
- Operation
- Maintenance

# 7x7 NG+4 SERIES PLANTERS MOUNTED RIGID FRAMES

(Serial No. 20A##### - )



## OPERATOR'S MANUAL

### 7x7 NG+4 SERIES PLANTERS MOUNTED RIGID FRAMES

OMM900002    ISSUE A1    (ENGLISH)

#### CALIFORNIA

##### Proposition 65 Warning

Diesel engine exhaust and some of its constituents are known to the State of California to cause cancer, birth defects, and other reproductive harm.

If this product contains a gasoline engine:

### **WARNING**

The engine exhaust from this product contains chemicals known to the State of California to cause cancer, birth defects or other reproductive harm.

The State of California requires the above two warnings.

Additional Proposition 65 Warnings can be found in this manual.

**MONOSEM, INC.**

North American Edition

PRINTED IN U.S.A.

# Introduction

## Foreword

READ THIS MANUAL carefully to learn how to operate and service your machine correctly. Failure to do so could result in personal injury or equipment damage.

THIS MANUAL SHOULD BE CONSIDERED a permanent part of your machine and should remain with the machine when you sell it.

USE only correct replacement parts and fasteners. Metric and inch fasteners may require a specific metric or inch wrench.

RIGHT-HAND AND LEFT-HAND sides are determined by facing in the direction the implement will travel when going forward.

WRITE PRODUCT IDENTIFICATION INFORMATION in the section below. Accurately record all the numbers to help in tracing the machine should it be stolen. Your dealer also needs these numbers when you order parts.

WARRANTY is provided as part of Monosem's support program for customers who operate and maintain their equipment as described in this manual. The warranty is printed inside the back cover of this manual.

This warranty provides you the assurance that Monosem will back its products where defects appear within the warranty period. Should the equipment be abused, or modified to change its performance beyond the original factory specifications, the warranty will become void and field improvements may be denied.

If you are not the original owner of this machine, it is in your interest to contact your local Monosem dealer to inform them of this unit's serial number. This will help Monosem notify you of any issues or product improvements.

Information in this manual is divided into sections. The section names are identified in the table of contents and at the top of each page. Each section has a unique number and page count. Specific information within each section is organized into topics identified with bold headings.

The topic headings are listed in the table of contents with the section number and page number where the topic begins. Topics and information related to each topic are also referenced in the index along with the section and page number.

The topic content flows down the left-hand side, then over and down the right-hand side, and repeats on the next page. Images precede the related text in the flow.

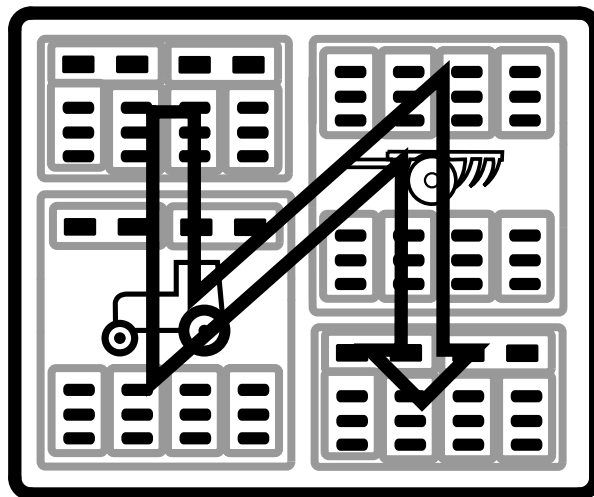

A100767 —UN—07JUN18

Continued on next page

HS35416,0000AF5 -19-28FEB19-1/2



# Contents

	Page		Page
<b>Safety</b>			
Recognize Safety Information .....	05-1	Hydraulic Connections Recommendations.....	20-4
Understand Signal Words.....	05-1	Check The Hydraulic System .....	20-5
Park Machine Safely.....	05-1	Attach the Warning Light Harness.....	20-5
Live With Safety.....	05-2	Warning Lights and Slow Moving Vehicle Emblem .....	20-6
Prevent Machine Runaway.....	05-2	Leveling The Planter.....	20-6
Handling Batteries Safely .....	05-3	Detach from Tractor .....	20-7
Prevent Battery Explosions .....	05-3	General Startup Points .....	20-7
Operate the Machine Safely .....	05-4	Hydraulic Motor Operation.....	20-7
Use Steps and Handholds Correctly .....	05-4	Support The Machine Before Service.....	20-8
Keep Riders Off Machine .....	05-4	Store the Machine .....	20-8
Prepare for Emergencies.....	05-5	Remove from Storage .....	20-9
Wear Protective Clothing.....	05-5	MOUNTED RIGID BAR.....	20-9
Handle Agricultural Chemicals Safely .....	05-6	AVAILABLE HITCH CONFIGURATIONS .....	20-10
Use Safety Lights and Devices.....	05-6		
Follow Tire Recommendations .....	05-7		
Transport Safely .....	05-8	<b>TRANSMISSION</b>	
Tow Loads Safely .....	05-9	7" x 7" 3pt Mounted and Stacking Toolbar Frame .....	30-1
Observe Maximum Transport Speed.....	05-9		
Practice Safe Maintenance.....	05-10	<b>VACUUM</b>	
Service Machine Safely .....	05-10	Standard Turbofan.....	40-1
Remove Paint Before Welding or Heating.....	05-11	High Output Turbofan .....	40-1
Avoid Heating Near Pressurized Fluid Lines .....	05-11	Extra High Output Turbofan.....	40-1
Auxiliary Hydraulic Attachment Operation .....	05-12	Before Planting Checklist .....	40-1
Store Attachments Safely .....	05-12	Vacuum Gauge Settings.....	40-5
Replace Safety Signs .....	05-12		
FOLLOWING OPERATION .....	05-13	<b>ROW UNIT</b>	
UNHOOKING THE PLANTER.....	05-13	NG Plus 4 Row Unit.....	50-1
STORING THE PLANTER .....	05-13	Seed Depth Adjustment.....	50-2
PERFORMING MAINTENANCE .....	05-14	Double Disc Openers .....	50-2
DRIVE LINE SAFETY.....	05-14	Replacing Double Discs .....	50-2
		V Press Wheels .....	50-3
<b>PREPARING THE PLANTER</b>		Seed Hopper .....	50-4
PREPARING THE PLANTER.....	10-1	Standard Down Pressure Springs .....	50-5
TRANSPORTING THE PLANTER .....	10-2	Seed Meter .....	50-5
OPERATING SPEED .....	10-2	Seed Tube .....	50-9
FIELD TEST .....	10-3	Seed Chute.....	50-10
CHECKING SEED POPULATION.....	10-3	Seed Disc .....	50-11
		Other Linkages .....	50-14
<b>FRAME MOUNTED RIGID FRAMES</b>		Metering Box Troubleshooting.....	50-15
Use Your Tractor Operator's Manual .....	20-1		
Add Weight to Tractor Front End.....	20-1	<b>OPTIONS</b>	
Planter Effective Weight .....	20-2	Quick- Adjust Down Pressure Springs .....	60-1
Set the Tractor Wheel Spacing.....	20-2	Monoshox® Option.....	60-1
Recommended Tractor Settings.....	20-2	Monoshox®Air Option .....	60-2
Case Drain and Hydraulic Motor Requirements .....	20-3		
Attach the Planter to the Tractor.....	20-3		

Continued on next page

*Original Instructions. All information, illustrations and specifications in this manual are based on the latest information available at the time of publication. The right is reserved to make changes at any time without notice.*

	<b>Page</b>
Slotted Collar .....	60-2
Pro-Wheel Intermediate Press Wheel Option.....	60-3
Sync-Row® System .....	60-4
Central Seed System.....	60-12
Setting Tank Pressure with Blower Eliminator ..	60-13
Microsem Microgranular Insecticide System ....	60-13
7085.SU.....	60-14
Insecticide Drop Tube.....	60-14
Setting The Output .....	60-15
How To Test for Insecticide Rates .....	60-16
Possible Sprocket Combinations.....	60-17
Trouble Shooting .....	60-17
Microsem Setting Chart - Drive Sprockets To Be Used.....	60-18
Liquid Fertilizer .....	60-19
Optional Piston Pump.....	60-21
Dry Fertilizer .....	60-23
Application Rates.....	60-26
US Insecticide System.....	60-27

# Safety

## Recognize Safety Information

This is a safety-alert symbol. When you see this symbol on your machine or in this manual, be alert to the potential for personal injury.

Follow recommended precautions and safe operating practices.



T81389 —UN—28JUN13

DX,ALERT -19-29SEP98-1/1

## Understand Signal Words

**DANGER;** The signal word DANGER indicates a hazardous situation which, if not avoided, will result in death or serious injury.

**WARNING;** The signal word WARNING indicates a hazardous situation which, if not avoided, could result in death or serious injury.

**CAUTION;** The signal word CAUTION indicates a hazardous situation which, if not avoided, could result in minor or moderate injury. CAUTION may also be used to alert against unsafe practices associated with events which could lead to personal injury.

A signal word—DANGER, WARNING, or CAUTION—is used with the safety-alert symbol. DANGER identifies the most serious hazards. DANGER or WARNING safety signs are located near specific hazards. General

precautions are listed on CAUTION safety signs. CAUTION also calls attention to safety messages in this manual.



**▲ WARNING**

**▲ CAUTION**

TS187 —19—30SEP88

DX,SIGNAL -19-05OCT16-1/1

## Park Machine Safely

Before working on the machine:

- Lower all equipment to the ground.
- Stop the engine and remove the key.
- Disconnect the battery ground strap.
- Hang a "DO NOT OPERATE" tag in operator station.

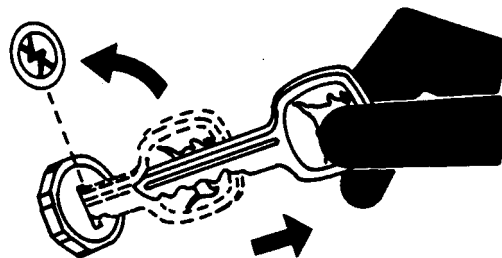

TS230 —UN—24MAY89

DX,PARK -19-04JUN90-1/1

### Live With Safety

Before returning machine to customer, make sure machine is functioning properly, especially the safety systems. Install all guards and shields.



TS231—19—07OCT88

DX,LIVE -19-25SEP92-1/1

### Prevent Machine Runaway

Avoid possible injury or death from machinery runaway.

Do not start engine by shorting across starter terminals. Machine will start in gear if normal circuitry is bypassed.

NEVER start engine while standing on ground. Start engine only from operator's seat, with transmission in neutral or park.

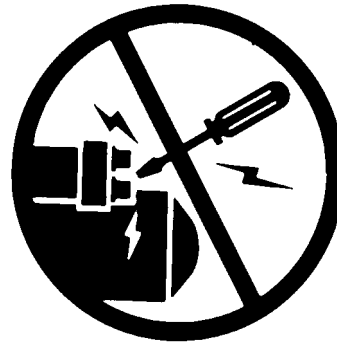

TS177—UN—11JAN89

DX,BYPAS1 -19-29SEP98-1/1



## Handling Batteries Safely

Battery gas can explode. Keep sparks and flames away from batteries. Use a flashlight to check battery electrolyte level.

Never check battery charge by placing a metal object across the posts. Use a voltmeter or hydrometer.

Always remove grounded (-) battery clamp first and replace grounded clamp last.

Sulfuric acid in battery electrolyte is poisonous and strong enough to burn skin, eat holes in clothing, and cause blindness if splashed into eyes.

### Avoid hazards by:

- Filling batteries in a well-ventilated area
- Wearing eye protection and rubber gloves
- Avoiding use of air pressure to clean batteries
- Avoiding breathing fumes when electrolyte is added
- Avoiding spilling or dripping electrolyte
- Using correct battery booster or charger procedure.

### If acid is spilled on skin or in eyes:

1. Flush skin with water.
2. Apply baking soda or lime to help neutralize the acid.
3. Flush eyes with water for 15—30 minutes. Get medical attention immediately.

### If acid is swallowed:

1. Do not induce vomiting.
2. Drink large amounts of water or milk, but do not exceed 2 L (2 qt.).
3. Get medical attention immediately.

**WARNING:** Battery posts, terminals, and related accessories contain lead and lead compounds, chemicals known to the State of California to cause cancer and reproductive harm. **Wash hands after handling.**



TS204—UN—15APR13

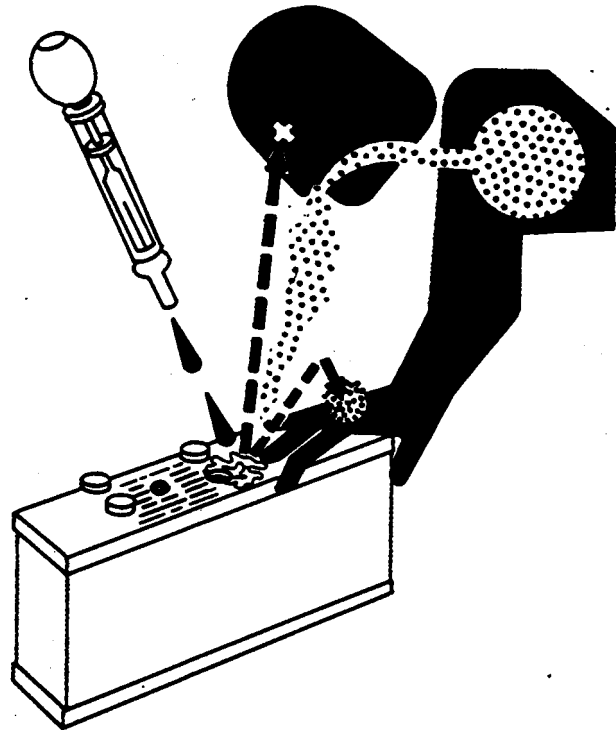

TS203—UN—23AUG88

DX,WW,BATTERIES -19-02DEC10-1/1

## Prevent Battery Explosions

Keep sparks, lighted matches, and open flame away from the top of battery. Battery gas can explode.

Never check battery charge by placing a metal object across the posts. Use a volt-meter or hydrometer.

Do not charge a frozen battery; it may explode. Warm battery to 16°C (60°F).



TS204—UN—15APR13

DX,SPARKS -19-03MAR93-1/1

### Operate the Machine Safely

Be careful when operating machine to avoid injury.

If the machine must be in a raised position while working on or near it, be certain service locks are installed or machine is adequately supported. Anytime hydraulic work must be done, lower the machine.

Serious injury or death can result from contact with electric lines. Use care when moving or operating this machine near electric lines to avoid contact.

Stand clear of machine when hydraulic components are being used. Mechanical or hydraulic failure can allow machine components to move rapidly.

Be sure cylinder and attaching hoses are fully charged with oil before operating system.

Be careful when operating system on hillsides; tractor can tip sideways if it strikes a hole, ditch or other irregularity.

Permit only one person, the operator, on tractor platform while tractor and machine are in operation.

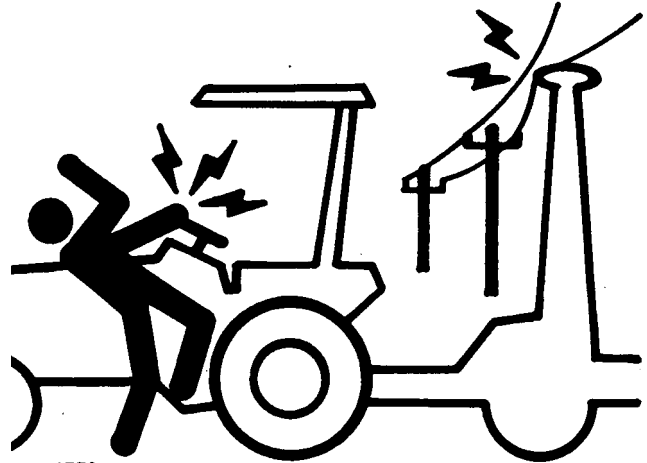

A34331

A34331 —UN—13OCT88

AG,OUO6074,1162 -19-04AUG00-1/1

### Use Steps and Handholds Correctly

Prevent falls by facing the machine when getting on and off. Maintain 3-point contact with steps, handholds, and handrails.

Use extra care when mud, snow, or moisture present slippery conditions. Keep steps clean and free of grease or oil. Never jump when exiting machine. Never mount or dismount a moving machine.

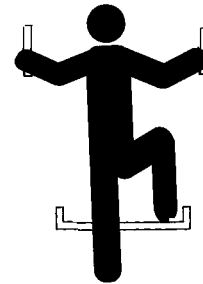

T133468 —UN—15APR13

DX,WW,MOUNT -19-12OCT11-1/1

### Keep Riders Off Machine

Only allow the operator on the machine. Keep riders off.

Riders on machine are subject to injury such as being struck by foreign objects and being thrown off of the machine. Riders also obstruct the operator's view resulting in the machine being operated in an unsafe manner.

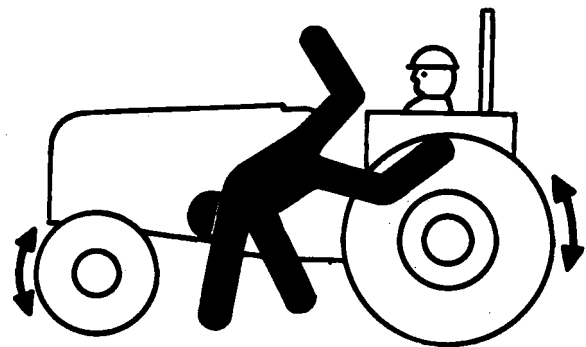

TS290 —UN—23AUG88

DX,RIDER -19-03MAR93-1/1

### Prepare for Emergencies

Be prepared if a fire starts.

Keep a first aid kit and fire extinguisher handy.

Keep emergency numbers for doctors, ambulance service, hospital, and fire department near your telephone.

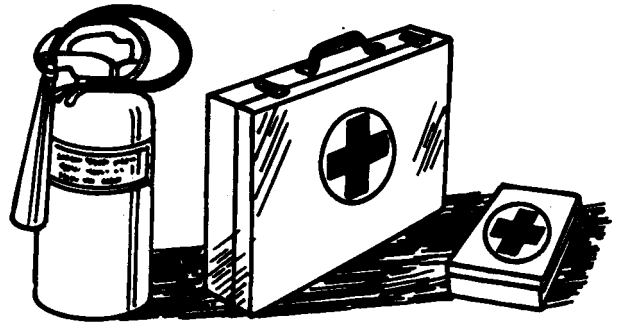

TS291—UN—15APR13

DX,FIRE2 -19-03MAR93-1/1

### Wear Protective Clothing

Wear close fitting clothing and safety equipment appropriate to the job.

Prolonged exposure to loud noise can cause impairment or loss of hearing.

Wear a suitable hearing protective device such as earmuffs or earplugs to protect against objectionable or uncomfortable loud noises.

Operating equipment safely requires the full attention of the operator. Do not wear radio or music headphones while operating machine.

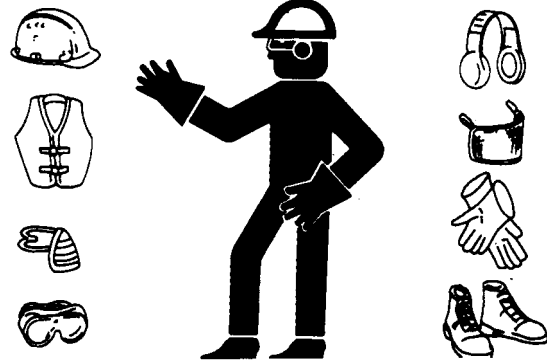

TS206—UN—15APR13

DX,WEAR -19-10SEP90-1/1

## Handle Agricultural Chemicals Safely

Chemicals used in agricultural applications such as fungicides, herbicides, insecticides, pesticides, rodenticides, and fertilizers can be harmful to your health or the environment if not used carefully.

Always follow all label directions for effective, safe, and legal use of agricultural chemicals.

Reduce risk of exposure and injury:

- Wear appropriate personal protective equipment as recommended by the manufacturer. In the absence of manufacturer's instructions, follow these general guidelines:
  - Chemicals labeled '**Danger**': Most toxic. Generally require use of goggles, respirator, gloves, and skin protection.
  - Chemicals labeled '**Warning**': Less toxic. Generally require use of goggles, gloves, and skin protections.
  - Chemicals labeled '**Caution**': Least toxic. Generally require use of gloves and skin protection.
- Avoid inhaling vapor, aerosol or dust.
- Always have soap, water, and towel available when working with chemicals. If chemical contacts skin, hands, or face, wash immediately with soap and water. If chemical gets into eyes, flush immediately with water.
- Wash hands and face after using chemicals and before eating, drinking, smoking, or urination.
- Do not smoke or eat while applying chemicals.
- After handling chemicals, always bathe or shower and change clothes. Wash clothing before wearing again.
- Seek medical attention immediately if illness occurs during or shortly after use of chemicals.
- Keep chemicals in original containers. Do not transfer chemicals to unmarked containers or to containers used for food or drink.

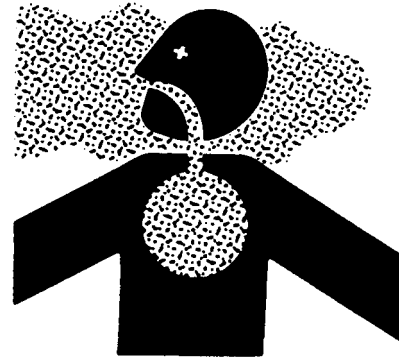

A34471

- Store chemicals in a secure, locked area away from human or livestock food. Keep children away.
- Always dispose of containers properly. Triple rinse empty containers and puncture or crush containers and dispose of properly.

DX,WW,CHEM01 -19-24AUG10-1/1

TS220—UN—15APR13

A34471—UN—11OCT88

## Use Safety Lights and Devices

Prevent collisions between other road users, slow moving tractors with attachments or towed equipment, and self-propelled machines on public roads. Frequently check for traffic from the rear, especially in turns, and use turn signal lights.

Use headlights, flashing warning lights, and turn signals day and night. Follow local regulations for equipment lighting and marking. Keep lighting and marking visible, clean, and in good working order. Replace or repair lighting and marking that has been damaged or lost.

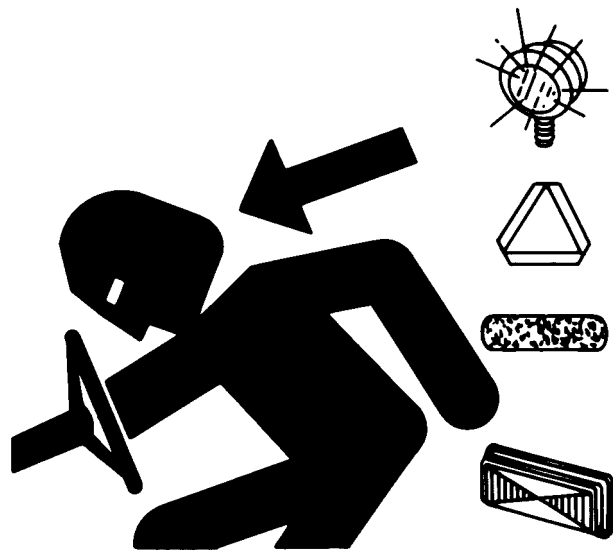

HS35416,0000A7B -19-01JAN19-1/1

TS951—UN—12APR90

## Follow Tire Recommendations

Keep your machine in proper working order.

Use only prescribed tire sizes with correct ratings and inflate to the pressure specified in this manual.

Use of other than prescribed tires may decrease stability, affect steering, result in premature tire failure, or cause other durability or safety issues.

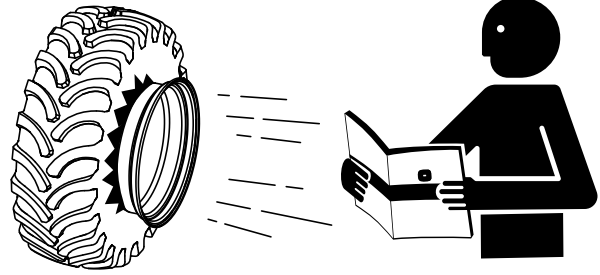

H111235 —UN—13MAY14

DX,TIRE,INFO -19-19MAY14-1/1

## Transport Safely

Avoid serious injury or death resulting from loss of control or rear end collision while transporting the planter and any load towed behind the tractor.

Always raise the parking stand before transport.

Tractor brakes must be latched together.

Attach a properly sized safety chain at each drawbar connection.

Shift the tractor into a lower gear when transporting down steep slopes or hills.

Always travel at a reasonable and safe speed (See Tow Loads Safely).

Never transport the planter when more than half full of product.

Always use the flashing warning lights, both day and night, when transporting on a public roadway.

Keep all the reflective material clean and visible.

Prevent collisions between motorists and slow moving equipment on public roads. Frequently check for traffic from the rear, especially during turns. Use the turn signals.

Keep everyone clear of the planter.

For stability and operator safety, the tractor must be properly ballasted.

Know the transport height and width of the planter.

Avoid serious injury or death, keep the marker arms away from overhead power lines. Proceed cautiously under overhead power lines and around utility poles. Know the transport height of the planter.

The construction of this planter may not meet all local or national requirements for transport on a public roadway. In regions or countries that have national certification requirements for roadway transport, it may be possible for this planter to be approved for such roadway transport. The customer is responsible for understanding and complying with all local, regional, and national requirements regarding roadway transport.

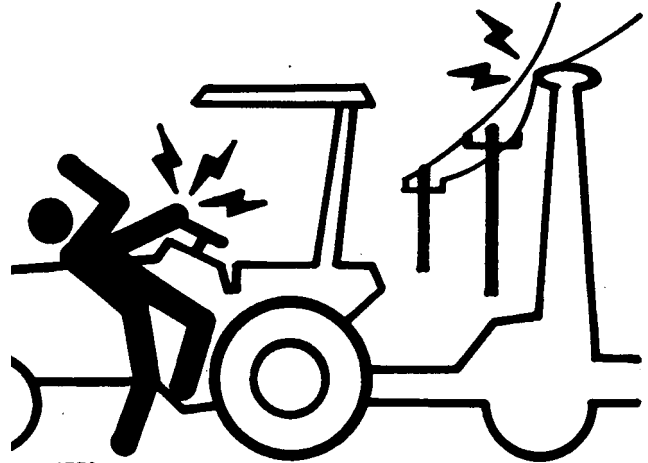

A34331

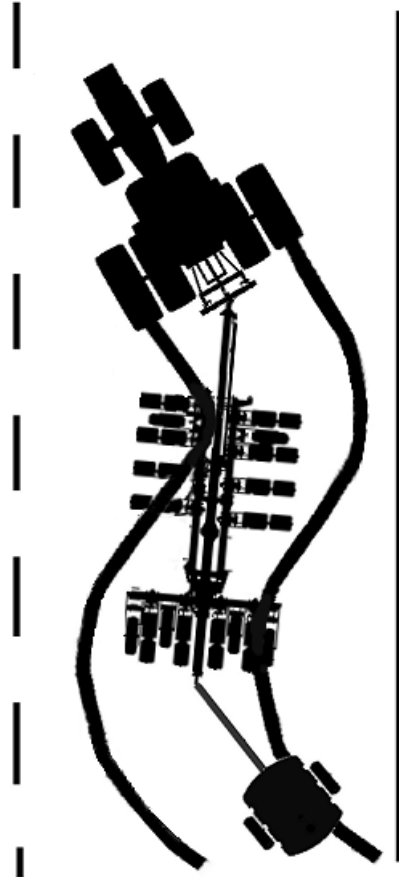

A34331—UN—13OCT88

A53085—UN—23OCT03

HS35416,0000A74 -19-01JAN19-1/1

## Tow Loads Safely

Stopping distance increases with speed and weight of towed loads, and on slopes. Towed loads with or without brakes that are too heavy for the tractor or are towed too fast can cause loss of control. Consider the total weight of the equipment and its load.

Observe these recommended maximum road speeds, or local speed limits which may be lower:

- If towed equipment does not have brakes, do not travel more than 32 km/h (20 mph) and do not tow loads more than 1.5 times the tractor weight.
- If towed equipment has brakes, do not travel more than 40 km/h (25 mph) and do not tow loads more than 4.5 times the tractor weight.

Ensure the load does not exceed the recommended weight ratio. Add ballast to recommended maximum for tractor, lighten the load, or get a heavier towing unit. The

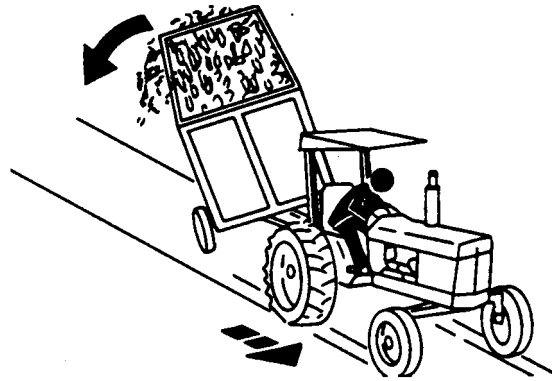

tractor must be heavy and powerful enough with adequate braking power for the towed load. Use additional caution when towing loads under adverse surface conditions, when turning, and on inclines.

TS216—UN—23AUG88

DX,TOW -19-02OCT95-1/1

## Observe Maximum Transport Speed

**The maximum transport speed for this implement is 32 km/h (20 mph).**

Some tractors are capable of operating at speeds that exceed the maximum transport speed of this implement. Regardless of the maximum speed capability of the tractor being used to tow this implement, do not exceed the implement's maximum transport speed.

Exceeding the implement's maximum transport speed can result in:

- Loss of control of the tractor/implement combination
- Reduced or no ability to stop during braking
- Implement tire failure
- Damage to the implement structure or its components

Use additional caution and reduce speed when towing under adverse surface conditions, when turning, and when on inclines.

Do not attempt transport if the fully loaded implement weighs more than 1.5 t (3 300 lb) and more than 1.5 times the weight of the tractor.

**Never tow this implement with a motor vehicle. Tow only with a properly ballasted tractor.**

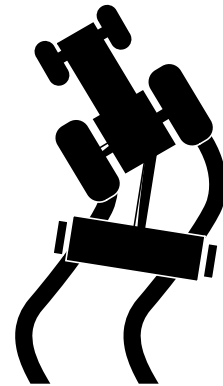
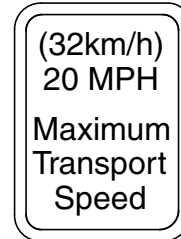

A46805—19—16JUL10

DX,TOW2 -19-11APR07-1/1

## Practice Safe Maintenance

Understand service procedure before doing work. Keep area clean and dry.

Never lubricate, service, or adjust machine while it is moving. Keep hands, feet, and clothing away from power-driven parts. Disengage all power and operate controls to relieve pressure. Lower equipment to the ground. Stop the engine. Remove the key. Allow machine to cool.

Securely support any machine elements that must be raised for service work.

Keep all parts in good condition and properly installed. Fix damage immediately. Replace worn or broken parts. Remove any buildup of grease, oil, or debris.

On self-propelled equipment, disconnect battery ground cable (-) before making adjustments on electrical systems or welding on machine.

On towed implements, disconnect wiring harnesses from tractor before servicing electrical system components or welding on machine.

Falling while cleaning or working at height can cause serious injury. Use a ladder or platform to easily reach each location. Use sturdy and secure footholds and handholds.



DX,SERV -19-28FEB17-1/1

TS218 —UN—23AUG88

## Service Machine Safely

To help prevent personal injury caused by unexpected movement, be sure to service planter on level surface.

If planter is connected to tractor, engage parking brake and/or place transmission in "PARK", shut off engine and remove key.

If planter is detached from tractor, block wheels and use safety stands to prevent movement.

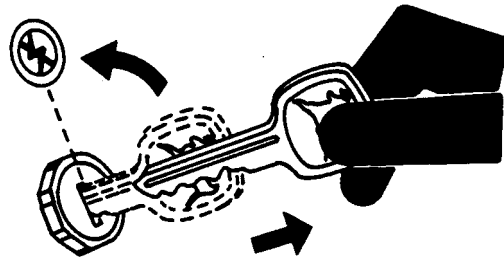

OM63945A,05F -19-28MAY19-1/1

TS230 —UN—24MAY89



### Remove Paint Before Welding or Heating

Avoid potentially toxic fumes and dust.

Hazardous fumes can be generated when paint is heated by welding, soldering, or using a torch.

Remove paint before heating:

- Remove paint a minimum of 100 mm (4 in.) from area to be affected by heating. If paint cannot be removed, wear an approved respirator before heating or welding.
- If you sand or grind paint, avoid breathing the dust. Wear an approved respirator.
- If you use solvent or paint stripper, remove stripper with soap and water before welding. Remove solvent or paint stripper containers and other flammable material from area. Allow fumes to disperse at least 15 minutes before welding or heating.

Do not use a chlorinated solvent in areas where welding will take place.

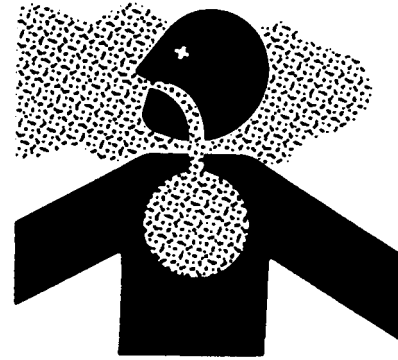

Do all work in an area that is well ventilated to carry toxic fumes and dust away.

Dispose of paint and solvent properly.

DX,PAINT -19-24JUL02-1/1

TS220 —UN—15APR13

### Avoid Heating Near Pressurized Fluid Lines

Flammable spray can be generated by heating near pressurized fluid lines, resulting in severe burns to yourself and bystanders. Do not heat by welding, soldering, or using a torch near pressurized fluid lines or other flammable materials. Pressurized lines can accidentally burst when heat goes beyond the immediate flame area.



DX,TORCH -19-10DEC04-1/1

TS953 —UN—15MAY90

### Auxiliary Hydraulic Attachment Operation

Remote hydraulic outlet at rear of planter for auxiliary hydraulic equipment operation.

**CAUTION:** Escaping fluid under pressure penetrates the skin causing serious injury. Avoid the hazard by relieving pressure before disconnecting hydraulic or other lines. Tighten all connections before applying pressure. Search for leaks with a piece of cardboard. Protect hands and body from high-pressure fluids.

Hydraulic hoses fail due to physical damage, kinks, age, and exposure. Check hoses regularly. Replace damaged hoses.

**IMPORTANT:** All hydraulic couplers must be clear of debris, dust, and sand. Use protective caps on

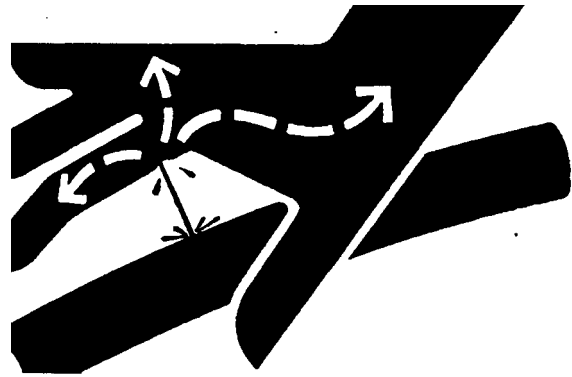

fluid openings until ready to make connection. Foreign material damages the hydraulic system.

HS35416,0000A75 -19-01JAN19-1/1

X9811 —UN—23AUG88

### Store Attachments Safely

Stored attachments such as dual wheels, cage wheels, and loaders can fall and cause serious injury or death.

Securely store attachments and implements to prevent falling. Keep playing children and bystanders away from storage area.



DX,STORE -19-03MAR93-1/1

TS219 —UN—23AUG88

### Replace Safety Signs

Replace missing or damaged safety signs. Use this operator's manual for correct safety sign placement.

There can be additional safety information contained on parts and components sourced from suppliers that is not reproduced in this operator's manual.

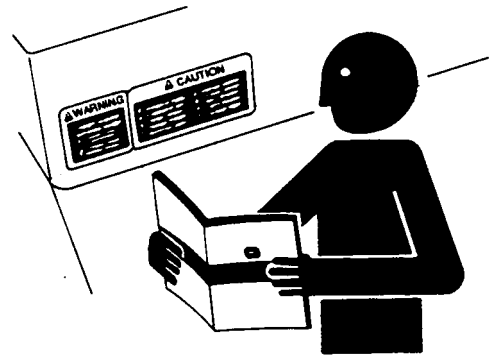

DX,SIGNS -19-18AUG09-1/1

TS201 —UN—15APR13

## FOLLOWING OPERATION

• When you stop operation of the planter, even if periodically, stop the tractor, set the tractor or towing vehicle brakes, disengage the PTO and all power drives, shut off the engine and remove the ignition key.

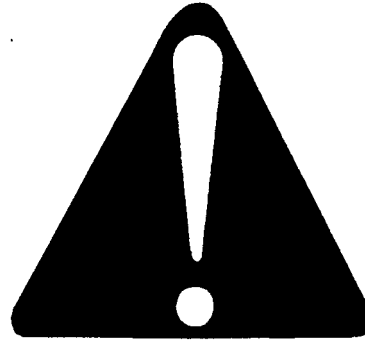

T81389 —UN—28JUN13

HS35416,0000A76 -19-01JAN19-1/1

## UNHOOKING THE PLANTER

Lower the toolbar stands to support the planter. Do not stand between the tractor and the planter when connecting or disconnecting the implement.

Before unhooking the planter from the tractor, fully extend the jack stands to the point where the toolbar will remain level. Lock the stands securely in place with the locking pins.

Lower the planter to the ground. Set the tractor or towing vehicle brakes, disengage PTO and all power drives, shut off the engine and remove the ignition key.

Unhook the tractor lift arms from hitch pockets and remove center link. If a quick attach is used, position levers so that the locking mechanism is in the “unlatched” position and lower.



T81389 —UN—28JUN13

When the lift arms or quick attach arms are clear of the tractor, slowly drive the tractor away from the planter.

HS35416,0000A77 -19-01JAN19-1/1

## STORING THE PLANTER

Store the planter on a dry, level surface. An uneven surface could cause the planter to shift or fall, resulting in injury or death. Store planter in an area away from human activity.

Do not permit children to play on or around the stored planter.

The planter should be stored in a dry and dust-free location with the hydraulic cylinders closed.

Engage all safety devices for storage.

You may need wheel chocks to prevent the parked planter from rolling.

Never work under the planter while in raised position without installing safety lockup pin



T81389 —UN—28JUN13

HS35416,0000A78 -19-01JAN19-1/1

## PERFORMING MAINTENANCE

Good maintenance is your responsibility.

Make repairs in an area with plenty of ventilation. Never operate the engine of the towing vehicle in a closed building. The exhaust fumes may cause asphyxiation.

As a precaution, always recheck the hardware on equipment following every 100 hours of operation. Correct all problems.

Before working on the planter, stop the towing vehicle, set the brakes, disengage the PTO and all power drives, shut off the engine and remove the ignition keys.

Never work under the planter while it is in a raised position.

Be certain all moving parts have come to a complete stop before attempting to perform maintenance.

Always use the proper tools or equipment for the job at hand.

Never use your hands to locate a hydraulic leak. Use a small piece of cardboard or wood. Hydraulic fluid escaping under pressure can penetrate the skin. If injured by escaping hydraulic fluid, see a doctor at once. Gangrene can result. Without immediate medical treatment, serious infection and reactions can occur.



Replace all shields and guards after servicing and before moving.

After servicing, remove all tools, parts and service equipment from on or in the planter.

If the planter has been altered in anyway from the original design, the manufacturer does not accept any liability for injury or warranty.

Any alterations to the design of this planter may create safety hazards. Follow safe practices to avoid injury.

HS35416,0000A79 -19-01JAN19-1/1

T81389 —UN—28JUN13

## DRIVE LINE SAFETY

Contact with a Rotating drive line can cause death – keep away. Do not operate without all driveline shields turn freely on driveline.



HS35416,0000A7A -19-01JAN19-1/1

TS1644 —UN—22AUG95

# PREPARING THE PLANTER

## PREPARING THE PLANTER

For the initial preparation of the planter, lubricate the planter and row units. Make sure all tires are evenly inflated, that all drive chains have the proper tension, alignment and lubrication.

**CAUTION:** Before starting up the planter, check that all main bolts are properly tightened and that planting units are equipped with the proper seed disc. Also check that the shutters inside the metering boxes are adjusted correctly (see Row Unit section). Check daily to see if the bolts of the hitch are tight.

**WARNING!** : The PTO shaft should be at a reduced angle during lifting. If the angle is too steep, reduce the PTO speed at the end of the field. (Normally the seed will remain under suction even at 400 rpm.)

### LUBRICATION

Frequency of lubrication for:

#### Chain lubricant

##### 50 hr.

- Unit drive chains
- Wheel block drive chains
- Transmission chains & rollers
- Insecticide drive chains
- Liquid fertilizer squeeze pump drive
- Chain rollers and shafts on unit

#### Grease

##### 10 hr.

- Gauge wheel arms
- Row marker hinge points

##### 50 hr.

- Frame Hinges/Joints

##### 200 hr.

- Wheel Hubs

**NOTE:** Extreme operating conditions such as excessive dirt, temperature or speed may require more frequent lubrication

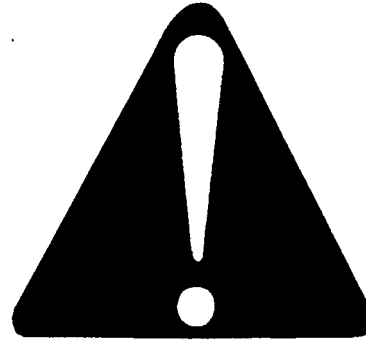

T81389—UN—28JUN13

### LUBRICATE WHEEL BEARINGS

Wheel bearings should be repacked with clean, heavy-duty axle grease every 4-5 seasons. This applies to all drive wheels, transport wheels, and marker hubs.

### LUBRICATE GREASE FITTINGS

Those parts equipped with grease fittings should be lubricated at the frequency indicated with high quality SAE grease. Be sure to clean the fitting thoroughly before using a grease gun. The frequency of lubrication recommended is based on normal operating conditions. Severe or unusual conditions may require more frequent lubrication.

### CHAIN TENSION ADJUSTMENT

The drive chains are spring loaded and therefore self-adjusting. The only adjustment needed is to shorten the chain if wear stretches the chain and reduces spring tension. The pivot point of these idlers should be checked periodically to ensure they would rotate freely.

### TIRE PRESSURE

Tire pressure should be checked regularly and maintained as follows:

3pt mounted		
ground drive	7.60 x 15	35 PSI (7x7)
	5.90 x 15	36 PSI (5x5)
Pull type rigid, Wingfold		
Transport	7.50-20	48 PSI
Contact drive	4.10-6	10 PSI

Continued on next page

HS35416,0000D4A -19-25JUN19-1/2

**DANGER**

Rim and tire servicing can be dangerous. Explosive separation of a tire and rim parts can cause serious injury or death.

Do not attempt to mount a tire unless you have the proper equipment and experience to perform the job. Only properly trained and equipped people should do this job.

Maintain the correct tire pressure. Do not inflate the tires above the recommended pressure.

When inflating tires, use a slip-on air chuck and extension hose long enough to allow you to stand to one side, and not in front of or over the tire assembly. Use a safety cage to enclose the tire and assembly when inflating.

Inspect tires and wheels daily. Do not operate with low pressure, cuts, bubbles, damaged rims or missing lug bolts and nuts.

**IMPORTANT:** Check daily to see if the bolts of the hitch are tight.

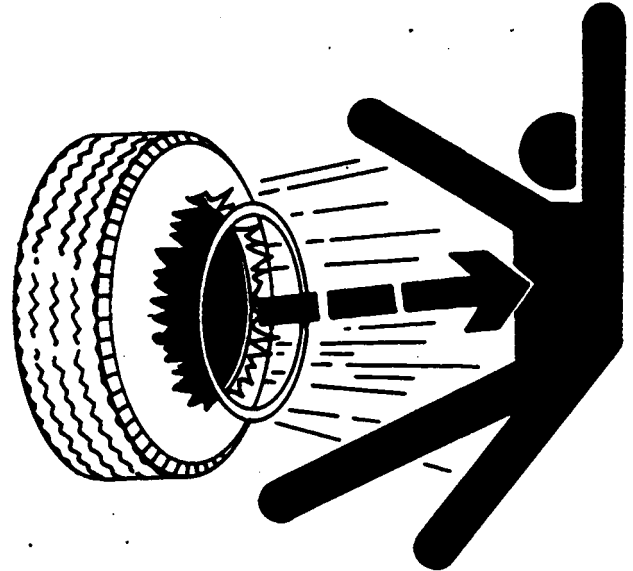

TS211 —UN—15APR13

HS35416,0000D4A -19-25JUN19-2/2

**TRANSPORTING THE PLANTER**

**CAUTION:** Use necessary safety precautions such as safety lights and devices.

Observe legal regulations before transporting the planter on public roads.

The Maximum transport speed for this planter is 10 MPH, or 16 km/h. **DO NOT EXCEED.** Never travel at any speed

that does not permit adequate control of steering and stopping.

Do not carry passengers on transported equipment.

Make sure to clear any obstructions overhead and to the side of the implement while transporting.

Make allowances for increased length and weight of the planter when making turns, stopping, etc.

HS35416,0000D4B -19-25JUN19-1/1

**OPERATING SPEED**

The operating speed needs to be selected as a function of:

- The desired consistency in the row
- The ground conditions
- The density of the seed

**OPERATING SPEED**

A high speed is not conducive to accuracy, especially in rough or rocky conditions that causes the unit to bounce.

Likewise, a high seed density may cause the disc to rotate fast, thus burdening the metering.

It should be noted, and especially for corn, that misshapen and angular seeds are difficult to sow regularly, particularly at high working speeds.

A base speed of 3 ½ to 4 ½ mph (5-7 km/h) assures good results for most seeds in the majority of conditions. However, when planting corn at lighter population more than 6" (15 cm) between the seed, 5- 6 mph (8-10 km/h) is quite possible.

For planting high seed population such as peanuts, edible beans, and kidney beans, best results can be obtained by not going faster than 3-4 mph (4.5-6 km/h).

HS35416,0000D4C -19-25JUN19-1/1

## FIELD TEST

Before the initial operation of the planter, a field test is advised. Check for the following:

- That the planter is level (front to back and side to side) (see Level Integral Machines)
- Check that the hydraulics of the 3-point hitch of the tractor is in a float position while planting.
- That all of the row units are running level and remain parallel to the ground when planting.

- Check that each metering unit is metering properly (see Row Unit section).
- Check that the seed disc has the proper number of holes and proper diameter of holes for the type of seed you will be planting (see Seed Disc chart in Row Unit section).
- Check for the proper application rates of chemicals on all rows.
- Check the desired seed depth and population. (see Row Unit section).

HS35416,0000D4D -19-25JUN19-1/1

## CHECKING SEED POPULATION

1. Only one planting unit is necessary to check seed population. Tie up the sets of closing wheels on one unit with a heavy cord or light chain. It may be necessary to decrease the tension of the closing wheel arm.
2. Put seed in the seed hopper.
3. Begin planting. At the end of a short distance (for example 100 yards or 90 meters) check to see if seed is visible in the seed trench. Make adjustments to seed depth if necessary.
4. Measure off 1/200 of an acre of the test row just planted. Use the chart below to find the approximate distance. Mark this distance with flags.

Count the seeds within the distance between the flags. Multiply the number of seeds counted in this distance by 200. This will give the total number of seeds planter per acre

Fraction Of Acre	Row Width			
	22"	30"	36"	40"
1/200	119	87	72 ½	66

**NOTE:** When viewing the test row for seed population and placement, remember that the closing wheels were tied up in a raised position. Therefore, the

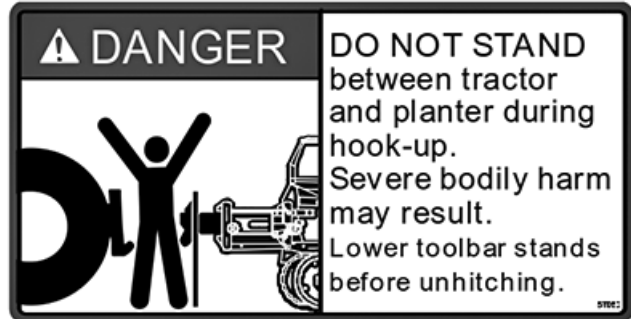

*seeds may have rolled or bounced and will affect the seed placement for accuracy.*

APY02900—UN—11FEB19

HS35416,0000D4E -19-25JUN19-1/1

# FRAME MOUNTED RIGID FRAMES

## Use Your Tractor Operator's Manual

Always refer to your tractor operator's manual for specific detailed information regarding the operation of your equipment.

The following tractor-related information uses John Deere™ tractors to illustrate preparation, attachment, and operational procedures. Use your tractor operator's manual for detailed information, as procedures vary by equipment.



TS190 —UN—17JAN89

HS35416,0000B74 -19-11JUN19-1/1

## Add Weight to Tractor Front End

**CAUTION:** Even with front-end ballast, stability is reduced if the tractor is driven too fast over rough ground with machine in raised position. Be safe and drive slow under these conditions.

Install the proper amount of weight on the front of the tractor as recommended in the tractor operator's manual. For proper front end weight, see the implement code tables if available.

The implement code number represents the weight of the implement and how far rearward the weight is from the tractor.

*NOTE: Dual rear wheels are required for stability and load capacity. A 12-row machine which weighs 10,375 pounds adds 16,375 pounds to the rear axle when the machine is raised.*

For tractor hitch lift requirements and front ballast requirements, use the implement code method on the following pages.



A68930 —UN—30SEP10

Determine the hitch lift compatibility first to determine if lift assist wheels are needed.

### Determine the Front-End Weight without Implement Codes

When implement code information is not available, see your tractor manual, your dealer, or qualified service provider.

HS35416,0000B75 -19-11JUN19-1/1



## Planter Effective Weight

Normally a tractor's 3 pt. hitch lift capacity is rated with the center of gravity (CoG) of the load at 24 inches behind the lower hitch pins. If the implement has a CoG other than 24 inches, it can 'feel' lighter or heavier. A distance greater than 24 inches would make the implement 'feel' heavier and the effective weight would therefore be important to know so that the tractor is not overloaded and can be properly ballasted.

Always read and understand the tractor's operator manual when attaching a 3 pt implements. This information is suggested to be used as a guide. It is the operator's responsibility to ensure the tractor and implement are used safely, both in the field and on the road during transport.

This formula should be used for row crop tractors with a minimum rated engine power of 200 Hp. If no exact CoG can be determined for the planter, make an estimate with some safety factor included.

!! Keep in mind that product weight such as seed or fertilizer will affect scale weight and CoG. !!

!! Keep in mind that a tractor's rated lift capacity may be what it can lift in the field, but is very likely not what it's rated to safely carry on the road. !!

$$EW = SW \times D/61 + SW \times 37/61$$

EW = Effective Weight ('Feels like' weight) in Lbs.

SW = Scale Weight in Lbs.

D = Center of gravity (CoG) horizontal distance to lower hitch pins (3pt) in Inches

Example: A 3pt planter fully loaded with product has a scale weight of 10,000 lbs. and a CoG horizontal distance of 48 inches to the lower hitch pins. The effective weight on the tractor would be :  $10,000 \times 48/61 + 10,000 \times 37/61 = 7,868.8 + 6,065.6 = 13,934.4$  lbs. Effective weight. Therefore, the additional CoG distance added about 39% to the scale weight of the loaded machine

HS35416,0000B76 -19-11JUN19-1/1

## Set the Tractor Wheel Spacing

*NOTE: On planters without drawbars, certain tire combinations require a Category 3N quick coupler to obtain wheel tread settings on 30 inch rows.*

**Single Wheels or Inner Dual Wheels** Set the wheels in, as far as possible, with the tread centers between the

planter rows (typically twice the row spacing on non-split row planters).

**Outer Dual Wheels** Set the dual wheels with the tread centers as close as possible between the planter rows (typically four times the row spacing on non-split row planters).

HS35416,0000B77 -19-11JUN19-1/1

## Recommended Tractor Settings

See Tractors Operator's Manual for complete operating instructions

Tractor Settings	
Item to set	Planter Models
Drawbar	Offset down or drawbar removed
Sway Blocks	On lift assist models, see Tractor Operators Manual to shim draft arms.
Three Point Links	Set for lateral float. See Tractor Operator's Manual.
Three Point Center Link	See Attaching Machine section for each configuration.
Hitch Control	Set to position control
Tire Ballast	Limit liquid or cast weight on rear tires <sup>a,b</sup>
Tractor Hydraulics	Closed Center Only Minimum tractor hydraulic pressure - 15 513 kPa (155 bar) (2250 psi) Working pressure - 20 684 kPa (207 bar) (3000 psi)
Tire Pressures	See Tractor Operator's Manual.
Hydraulic Controls	See HYDRAULIC CONNECTIONS RECOMMENDATIONS.

<sup>a</sup>Dual rear tractor tires are recommended for stability and for load carrying capacity, especially when the machine is folded for transport.

<sup>b</sup>To carry the machine for transport, limit liquid or cast wheel weights on rear tractor tires as tire load carrying capacity is decreased.

HS35416,0000B78 -19-11JUN19-1/1

## Case Drain and Hydraulic Motor Requirements

**IMPORTANT:** Most planter hydraulic configurations utilize hydraulic motors equipped with case drain connections. To avoid damage to the hydraulic motors, connect the case drain hose to the tractor with a low-pressure drain coupler. Install the coupler in a port with less than 25 psi.

The case drain hose (A) must be attached to a low-pressure drain connection before any other hose connection.

If tractor is not equipped with case drain connector, kits are available for a John Deere™ tractor. For other tractors, see the tractor dealer for a suitable connection kit.

Some hydraulic motors are low flow, high-pressure motors. The motors are designed to operate on a closed- center hydraulic system. Connecting low flow, high-pressure hydraulic motors to an open-center system

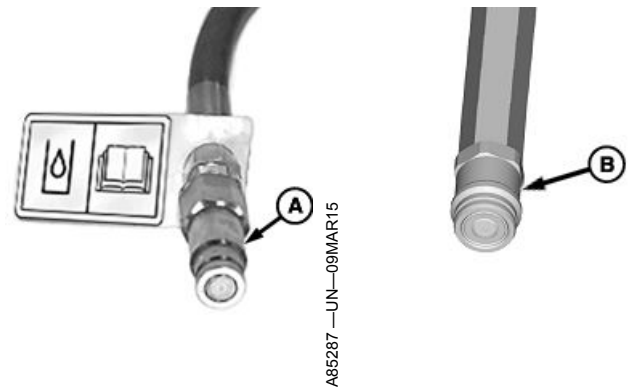

A— Machine Drain Coupler

B—Tractor Drain Connection

is not recommended. See your dealer or qualified service provider for more information.

HS35416,0000B79 -19-11JUN19-1/1

## Attach the Planter to the Tractor

**CAUTION:** Do not stand between the tractor and the planter unless the tractor transmission is in Park.

1. Place the hitch-load depth control in the Position setting for better control when hitching and during operation (Refer to the Tractor Operator's Manual).
2. Raise both quick-hitch latch control levers (A). Verify that the correct center-link top hook (B) is installed on the quick-hitch before proceeding.

**CAUTION:** To prevent possible injury during tractor attachment, only use hitch controls that move with incremental steps (Refer to the Tractor Operator's Manual).

3. Lower the rockshaft until the quick-hitch hooks are lower than the planter hitch pins. Slowly back the tractor up to the planter.

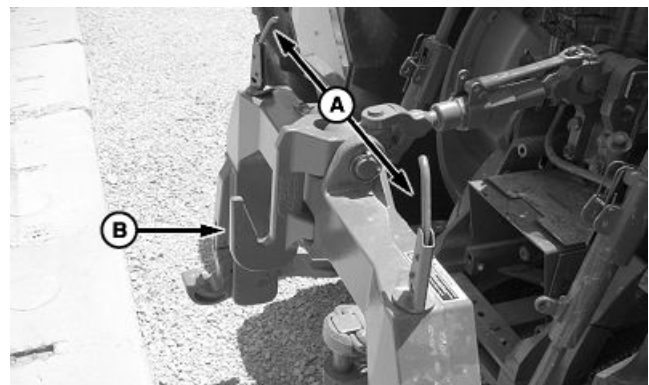

8030 Series Tractor Latch Levers Shown

A—Latch Control Levers

B—Category 3 Center Link Top Hook

4. Check the drawbar clearance. If the drawbar contacts the hitch or planter, turn the drawbar offset down and in the shortest possible position.

Continued on next page

HS35416,0000B7A -19-11JUN19-1/2

**CAUTION:** When the latch control levers (A) are properly locked, the handles are horizontal and against the hitch frame.

5. Raise the rockshaft enough to engage the planter hitch pins in the quick-hitch hooks. Push both latch control levers (A) down to lock the planter to the quick-hitch.
6. Check the tractor dual wheel tire clearance.
7. After the planter is attached to the tractor, remove the spring locking pin and drilled pin. Raise the support stands up and secure with the drilled pin and spring locking pin.

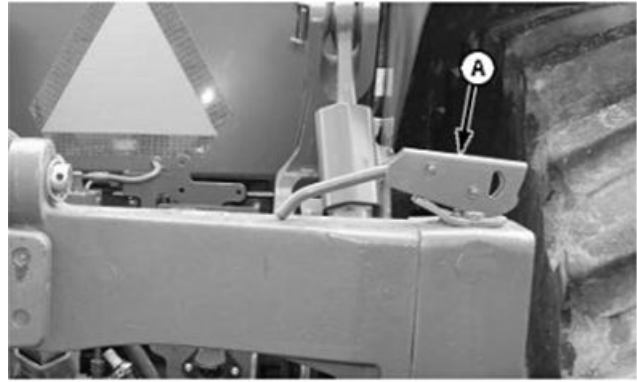

Locked Position

A—Latch Control Lever

APY02894—UN—11FEB19

HS35416,0000B7A -19-11JUN19-2/2

### Hydraulic Connections Recommendations

Extend and Retract symbols are on tractor selective control valve (SCV) cover.

Refer to tractor operator's manual for specific hydraulic operational details.

**CAUTION:** Avoid hydraulic hose failure due to physical damage, kinks, age, and exposure. Inspect hoses regularly. Replace damaged hoses.

**IMPORTANT:** Avoid motor seal damage. Connect the case drain hose before any other hose. Connect vacuum and variable rate drive (VRD) return hoses to a tractor “extend” SCV.

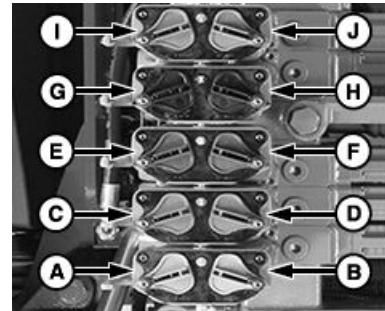

Tractor Valves

Avoid motor seal damage. Move tractor SCV lever to float (not neutral) position to shut off vacuum and VRD.

A82588—UN—23MAY14

HS35416,0000B7B -19-25JUN19-1/1

## Check The Hydraulic System

**⚠ CAUTION:** Escaping fluid under pressure can penetrate the skin and cause serious injury.

Relieve the hydraulic pressure before disconnecting the hydraulic or other lines to avoid this hazard. Tighten all of the hydraulic connections before applying pressure.

Search for leaks with a piece of cardboard. Protect your hands and your body from high-pressure fluids.

If an accident occurs, see a doctor immediately. Any fluid injected into your skin must be surgically removed within a few hours or gangrene can result. Doctors unfamiliar with this type of injury must reference a knowledgeable medical source.

Hydraulic hoses can fail due to physical damage, kinks, age, and exposure. Check the hoses regularly. Replace any damaged hoses.

After applying pressure to system, check all of the hydraulic connections and the hoses for leaks.

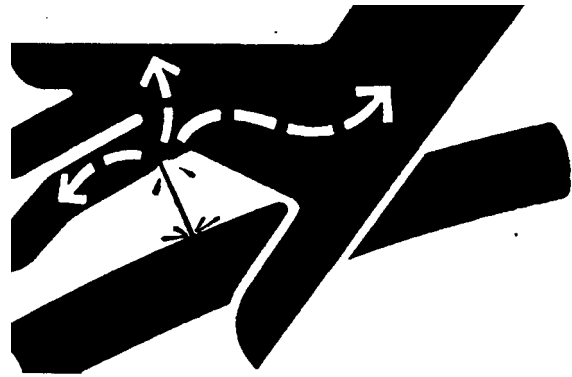

**IMPORTANT:** The tractor hydraulic oil level can drop below the operating level when operating the machine for the first time. Check the tractor hydraulic oil level after filling the cylinders with oil for the first time.

HS35416,0000B7C -19-11JUN19-1/1

X9811 —UN—23AUG88

## Attach the Warning Light Harness

Attach the warning light harness to the 7-pin connector.



HS35416,0000D3F -19-18JUN19-1/1

A85921 —UN—25MAR15

## Warning Lights and Slow Moving Vehicle Emblem

When transporting the planter on a roadway, use flashing warning lights and turn signals day and night. Prevent collisions between other road users.

**IMPORTANT:** The construction of this planter may not meet all local or national requirements for transport on a public roadway. In regions or countries that have national certification requirements for roadway transport, it may be impossible for this planter to be approved for such roadway transport. The customer is responsible for understanding and complying with all local, regional, and national requirements regarding roadway transport.

*NOTE: Keep reflective material and slow moving vehicle (SMV) emblem clean and visible.*

Keep lights visible, clean, and in working order.

Check local governmental regulations. Various safety devices are available from your John Deere dealer or qualified service provider. Keep safety items in good condition. Replace missing or damaged items.

*NOTE: Light and emblem placement vary according to local, regional, and national government regulations.*

Amber warning lights are positioned on the outer edge of each side of the planter. On integral planters, red lights are also positioned next to the amber lights.

Slow moving vehicle emblem is centralized on the rear of the planter.

HS35416.0000D40 -19-18JUN19-1/1

## Leveling The Planter

*NOTE: Set the frame height before leveling.*

1. Drive the tractor and planter onto level soil.
2. Lower the planter while driving forward.

**IMPORTANT:** With the planter lowered into the planting position, the tractor hitch must not carry any of the planter weight. The row units and the frame wheels support the planter weight. Adjust the tractor hitch links so that they do not support any of the planter weight. Level the frame front-to-rear with combined adjustments of the tractor center link (A) and the planter gauge wheels.

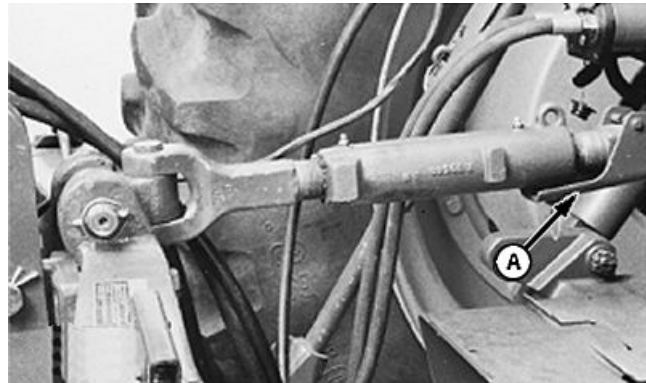

A—Tractor Center Link

A56304—UN—11MAY05

HS35416.0000D41 -19-27AUG19-1/2

3. Verify that the planting units (B) are parallel with the ground. Adjust the center link and gauge wheels as needed.

While planting, the parallel arms (C) should be parallel to ground or angle slightly upward toward the planter frame. The bottom of the toolbar should be approximately 19" above the ground.

4. Periodically verify that the planting units are level during operation.

B—Planting Units

C—Parallel Arms

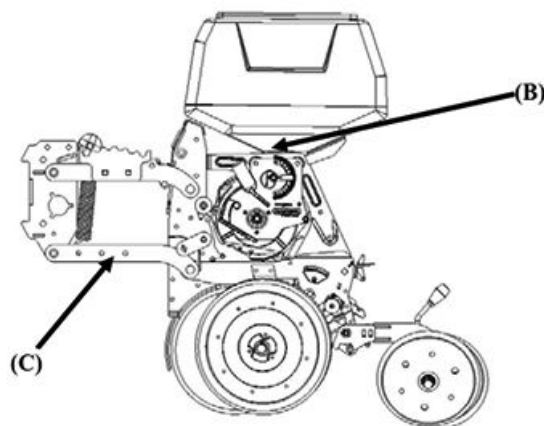

APY02893—UN—11FEB19

HS35416.0000D41 -19-27AUG19-2/2

## Detach from Tractor

**IMPORTANT:** Top of parking stand (B) must extend out the top of support tube (C) for stability.

1. Lower parking stand (B) and fasten with pin (A).
2. Lower machine to ground. See tractor operator's manual.
3. Place SCV levers in "Float" position.
4. Turn tractor key switch off.

**CAUTION:** Avoid injury from escaping hydraulic oil under pressure; relieve pressure in the system before removing hoses from breakaway couplers.

5. Disconnect all hydraulic hoses.
6. Disconnect warning light harness from 7-pin connector.
7. Disconnect monitor wiring harness.
8. Attach dust covers to harness connectors.
9. Disconnect machine from tractor.

A—Pin  
B—Stand

C—Support Tube

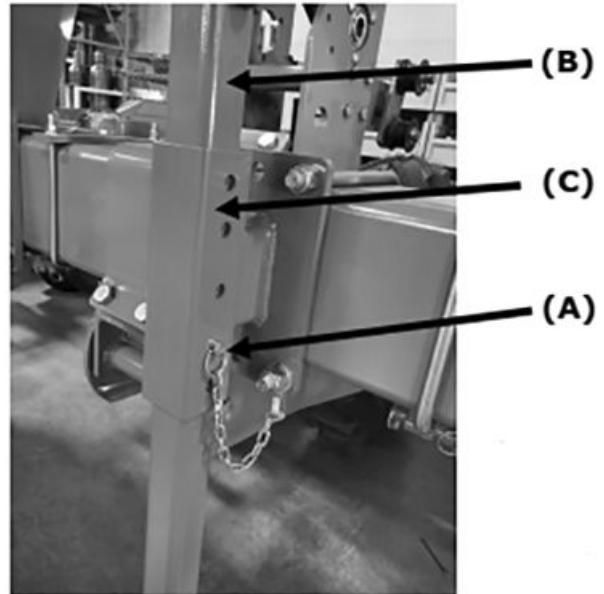

Detach from Tractor

APY19012 —UN—25JUN19

HS35416,0000D42 -19-19JUN19-1/1

## General Startup Points

**IMPORTANT:** Do not put the selective control valve (SCV) lever in the float position when raising and lowering the machine. Correct procedure for raising and lowering the machine is to power up or down completely.

1. To prevent plugging of the seed tubes or the seed openers, Do not back up with the machine lowered.

For proper machine operation, it is important that the machine frame is lowered fully into the correct planting position. Achieving this position can be difficult with some attachment combinations, especially when planting in hard to penetrate soil conditions. If this situation is encountered, the following action is warranted:

Reduce the attachment downforce levels. Avoid using more attachment downforce than required.

Use recommended size tractor. (See Tractor Requirements.)

2. Verify that the tractor and the planter have been properly prepared.
3. Check the seed rates carefully.
4. Check the tire pressure before seeding.
5. Allow the tractor hydraulic oil to warm up thoroughly before seeding.
6. Use clean seed for the best results.
7. Use detailed information about your planter attachments for the function and operation.

HS35416,0000D44 -19-19JUN19-1/1

## Hydraulic Motor Operation

Connect hoses correctly.

To engage hydraulic motors, move the selective control valve (SCV) lever forward (retract function) and engage the detent.

Avoid motor damage from pressure spikes in the hydraulic system. Move the SCV lever forward into "Float" position, not into "Neutral" position, to shut off hydraulic motors.

Once the hydraulic motors come to a stop, the SCV lever can be returned to "Neutral" position.

HS35416,0000D45 -19-19JUN19-1/1

## Support The Machine Before Service

**⚠ CAUTION: Avoid crushing injury or death from falling machine. Ensure service locks are installed on all cylinders and machine is supported on blocks before performing any service or adjustments.**

1. Raise the machine.
2. Place the support blocks under the gauge wheels.
3. Install the service locks on all of the lift cylinders.
4. Lower the machine onto the support blocks
5. Shift the tractor to "Park" and set the parking brake.

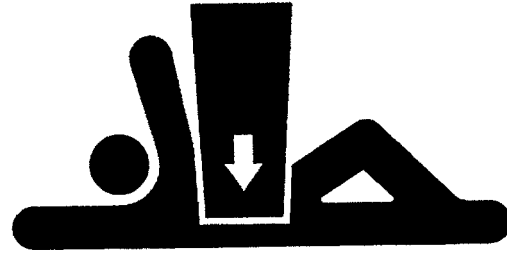

6. Stop the engine and remove the key.

HS35416,0000D46 -19-19JUN19-1/1

A44347—JUN—18DEC97

## Store the Machine

**⚠ CAUTION: Avoid skin, eye, and respiratory injury. Follow chemical manufacturer's precautions when handling parts coated with chemicals or treatments. Use proper skin, eye, and respiratory protection.**

**IMPORTANT: Avoid damage to electrical components, bearings, hoses, or hoppers. Avoid direct spray at sensitive components. Use caution, if power washing machine.**

When planting is completed for one season, store the machine under a cover with all parts in operating condition.

Clean the machine thoroughly to remove dirt and residue that holds moisture.

Paint all parts which are chipped or worn.

Lubricate the machine. Grease exposed cylinder rods.

Thoroughly lubricate the chains at beginning of the idle period.

Empty and clean the seed hoppers.

Clean the insecticide or herbicide hopper thoroughly as various chemicals deteriorate system components.

Clean the liquid and dry fertilizer components thoroughly as various fertilizers deteriorate system components.

Inspect the machine for worn or broken parts. See your dealer or qualified service provider during the off season to acquire parts or service when the machine is not needed in the field.

Store the machine in a clean, dry place with the wheels out of the sun.

Relieve the closing-wheel down force. Place the adjustment handle in the neutral setting.

Relieve the row unit down force.

Thoroughly flush the liquid herbicide system with clean water. Follow the chemical manufacturer's label.

**IMPORTANT: Store the seed disks away from extreme heat or direct sunlight. Do not leave the disks in the meters during the off season. Do not store the disks under heavy parts.**

Store the disks in the shipping box or hang on a wall.

Clean the meter housing, meter chamber, and seed disk compressed air

Clean the vacuum system.

Inspect the vacuum meter seals. Replace the seals as needed.

Check for hydraulic leaks.

HS35416,0000D47 -19-19JUN19-1/1

## Remove from Storage

Before using the machine after it has been stored, inspect the seed hoppers for cleanliness and verify that the seed passages are clear.

Thoroughly inspect the machine for loose parts and adjust as necessary.

**IMPORTANT: High-pressure washers can damage electrical components, bearings, hoses, and hoppers when direct spray is applied. Use caution, if power washing the machine.**

Clean any dirt or grease that accumulated on moving parts, gears, and chains before operating the machine. Cleaning prevents abrasive action that causes excessive wear.

**IMPORTANT: Do not use a heavy petroleum base lubricant that causes a buildup of dust or dirt in the sprocket or gear teeth.**

*NOTE: Rust buildup can become serious enough to cause the chain joints to stiffen, restricting the normal movement. Stiffness can cause abnormal operation, disturb the smooth rotation of important meter components, and cause a deterioration in performance.*

If the machine is not used for several days or if lube has been removed from the chains during cleaning, thoroughly lubricate the chains.

HS35416,0000D48 -19-19JUN19-1/1

## MOUNTED RIGID BAR

The mounted rigid 7"x7" frame is a double rigid toolbar frame, consisting of a heavy 3/8" wall 7"x7" square bottom toolbar and a 5"x5" or 4"x7" square top toolbar.

Several different hitch configurations are available, depending on the size and type of planter. Each hitch configuration is compatible with different hitch standards (CAT II, CAT III, etc.). See illustrations below for hitch configurations and compatible hitch standards.

To improve frame strength, additional supports between the bottom and top toolbars may be added along the width of the frame.

**⚠ CAUTION: The Maximum transport speed for this Mounted Bar is 10 MPH, or 16 km/h. DO NOT EXCEED. Never travel at any speed that does not permit adequate control of steering and stopping.**

HS35416,0000D49 -19-25JUN19-1/1



### AVAILABLE HITCH CONFIGURATIONS 7X7 COMBO HITCH

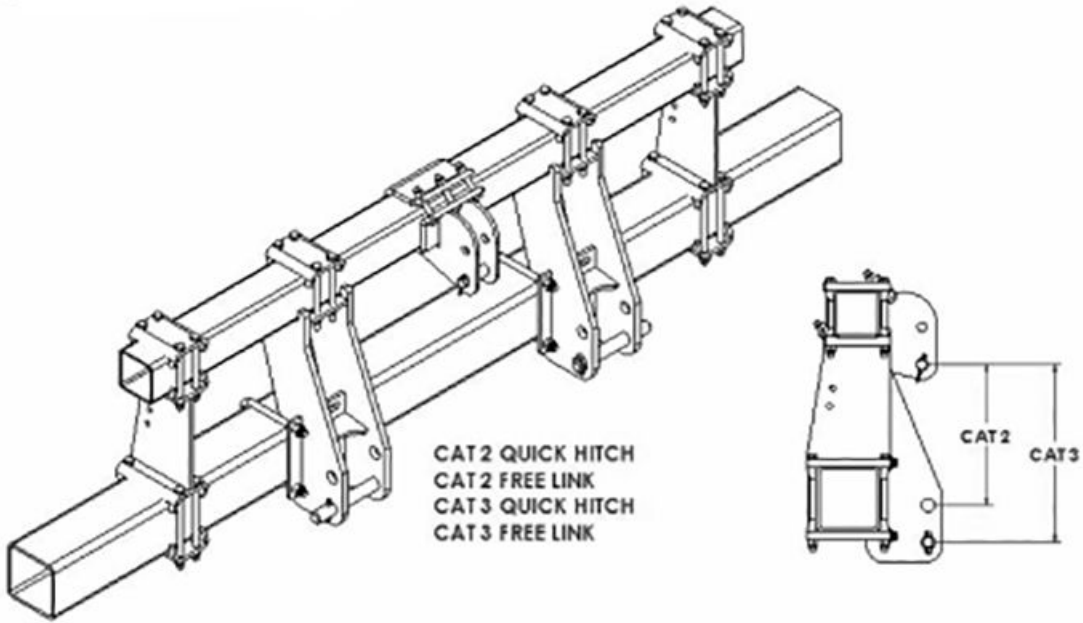

APY19013 —UN—25JUN19

HS35416,0000D77 -19-25JUN19-1/4

### 7X7 HITCH POCKETS

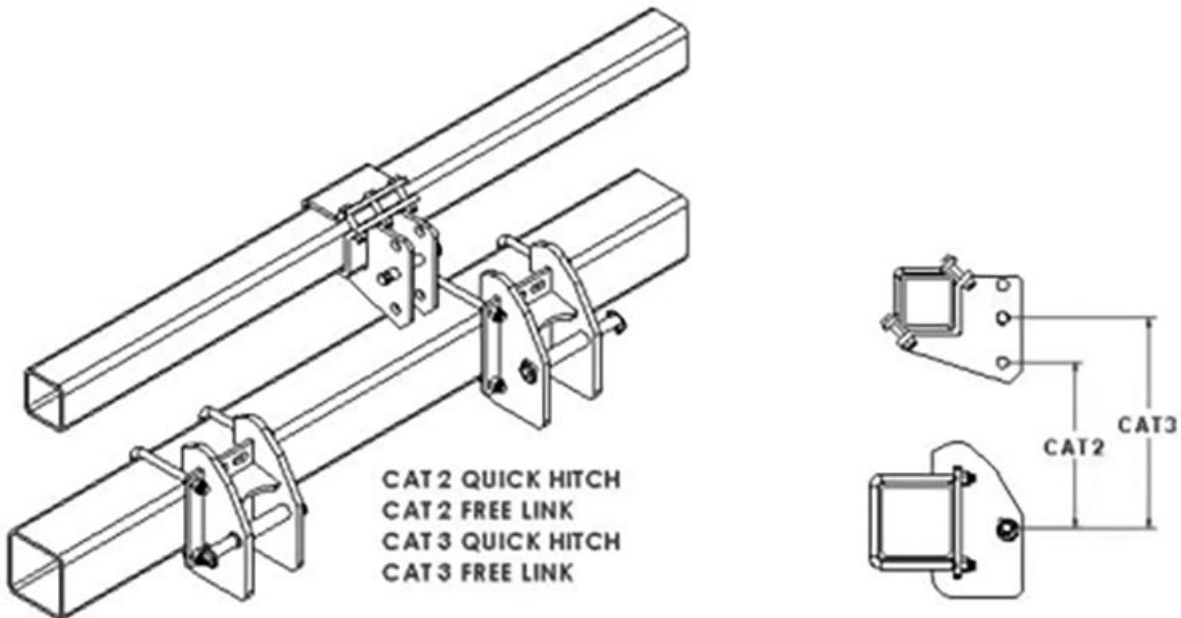

APY19014 —UN—25JUN19

Continued on next page

HS35416,0000D77 -19-25JUN19-2/4

**7X7 FULLY MOUNTED**

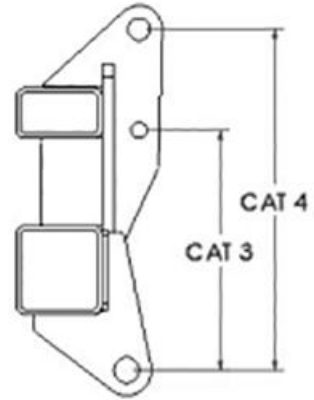
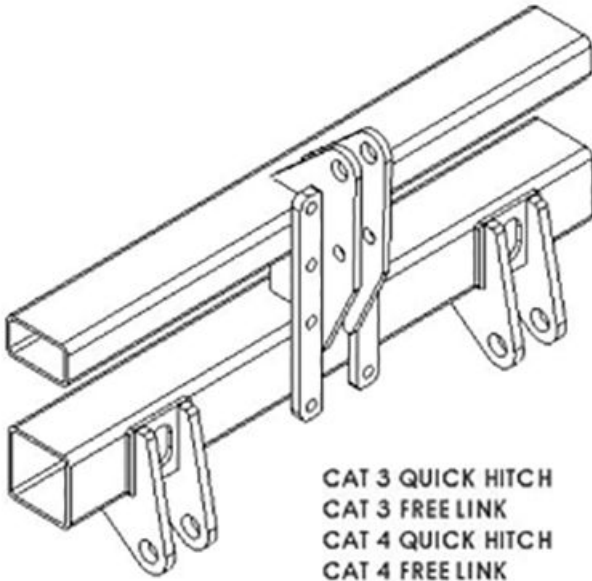

HS35416,0000D77 -19-25JUN19-3/4

APY19015 —UN—25JUN19

**7X7 DOUBLE TOOLBAR**

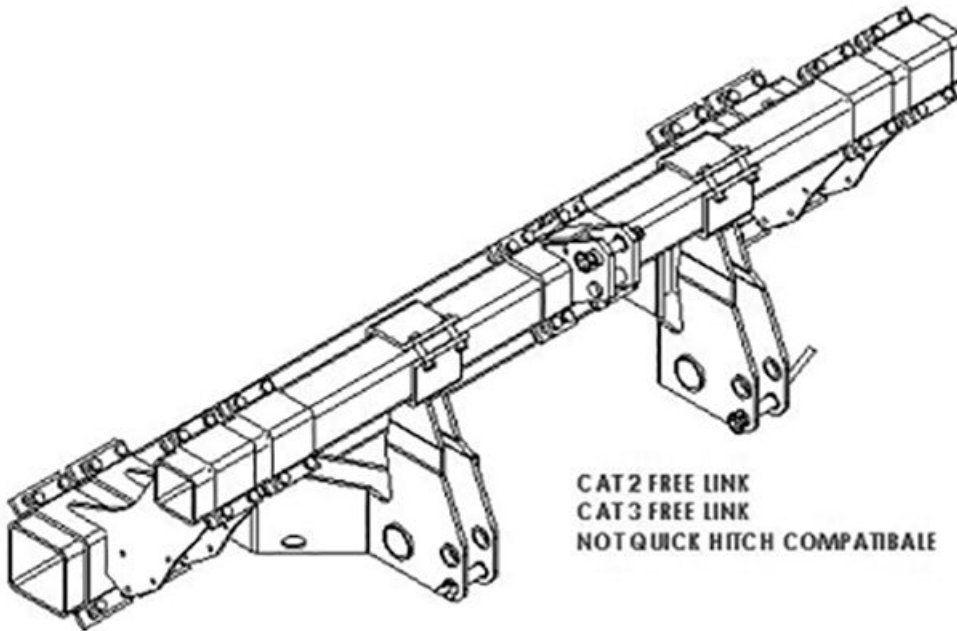

HS35416,0000D77 -19-25JUN19-4/4

APY19016 —UN—25JUN19

# TRANSMISSION

## 7" x 7" 3pt Mounted and Stacking Toolbar Frame

### PLANTING RATE CHART

#### 3pt Mounted & Stacking Planters

**IMPORTANT:** Poor alignment of the sprockets in the gearbox and stiffness of the chain will cause premature side wear on the pinions. Make sure the chains are tight and properly lubricated, and the tires are properly inflated. Improper tire inflation will affect seed spacing.

The indicated spacings are theoretical and may vary from 5-10% depending on soil conditions.

#### Low Seed Hole Seed Spacing Calculation

Divide 9 by the number of holes in your disc, this will give you a multiplier

**Example:** For a 3 hole plate;  $9 / 3 = 3$  (Multiplier)

Use the seed spacings in the row for a 9 hole plate; multiply any seed spacing in that row by the calculated multiplier.

**Example:** Seed spacing from chart 14.7" x 3 (Multiplier) = 44.1" (seed spacing for 3 hole plate at the given sprocket setting)

*NOTE:* A good way to determine seed spacing is dig up 11 consecutive seeds planted at a normal operating speed. Measure from seed 1 to seed 11 and divide by 10. The result is the average of the 10 spaces. This will provide an accurate representation of seed spacing

Monosem has an app available from the Apple App Store and Google Play. Look for the Monosem Inc. App for US (not EU)

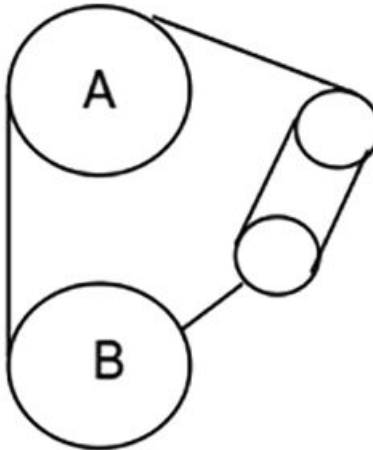

APY02899 —UN—11FEB19

### SOWING DISTANCES

Number of Holes in the Seed Disc

Transmission sprocket selection

	26	24	23	26	24	23	24	23	19	19	17	18	19	17	18	17	14	14	14
Driver A	26	24	23	26	24	23	24	23	19	19	17	18	19	17	18	17	14	14	14
Driver B	17	17	19	23	23	24	26	26	23	24	23	26	28	26	28	28	24	26	28
	Seed Spacing (inches)																		
9	7.9	8.6	10.0	10.7	11.6	12.7	13.1	13.7	14.7	15.3	16.4	17.5	17.9	18.6	18.9	20.0	20.8	22.5	24.3
12	6.0	6.4	7.5	8.1	8.7	9.5	9.9	10.3	11.0	11.5	12.3	13.1	13.4	13.9	14.2	15.0	15.6	16.9	18.2
18	4.0	4.3	5.0	5.4	5.8	6.3	6.6	6.9	7.3	7.7	8.2	8.8	8.9	9.3	9.4	10.0	10.4	11.3	12.1
24	3.0	3.2	3.8	4.0	4.4	4.7	4.9	5.1	5.5	5.7	6.2	6.6	6.7	7.0	7.1	7.5	7.8	8.5	9.1
30	2.4	2.6	3.0	3.2	3.5	3.8	3.9	4.1	4.4	4.6	4.9	5.3	5.4	5.6	5.7	6.0	6.2	6.8	7.3
36	2.0	2.1	2.5	2.7	2.9	3.2	3.3	3.4	3.7	3.8	4.1	4.4	4.5	4.6	4.7	5.0	5.2	5.6	6.1
40	1.8	1.9	2.3	2.4	2.6	2.8	3.0	3.1	3.3	3.4	3.7	3.9	4.0	4.2	4.2	4.5	4.7	5.1	5.5
48	1.5	1.6	1.9	2.0	2.2	2.4	2.5	2.6	2.8	2.9	3.1	3.3	3.4	3.5	3.5	3.7	3.9	4.2	4.6
60	1.2	1.3	1.5	1.6	1.7	1.9	2.0	2.1	2.2	2.3	2.5	2.6	2.7	2.8	2.8	3.0	3.1	3.4	3.6
72	1.0	1.1	1.3	1.3	1.5	1.6	1.6	1.7	1.8	1.9	2.1	2.2	2.2	2.3	2.4	2.5	2.6	2.8	3.0
90	0.79	0.86	1.00	1.07	1.16	1.27	1.31	1.37	1.47	1.53	1.64	1.75	1.79	1.86	1.89	2.00	2.08	2.25	2.43
120	0.60	0.64	0.75	0.81	0.87	0.95	0.99	1.03	1.10	1.15	1.23	1.31	1.34	1.39	1.42	1.50	1.56	1.69	1.82

HS35416,0000D4F -19-25JUN19-1/1

ROW SPACING (INCHES)														
			TWIN ROW 30"	TWIN ROW 36"	TWIN ROW 38"	TWIN ROW 40"								
Avg. Row Spacing	10	12	15	18	19	20	22	26	30	34	36	38	40	
1	627,300	522,700	418,200	348,500	330,100	313,600	285,100	241,300	209,100	184,500	174,200	165,100	156,800	
1 1/2	418,200	348,500	278,800	232,300	220,100	209,100	190,100	160,800	139,400	123,000	116,200	110,000	104,500	
2	313,600	261,400	209,100	174,200	165,100	156,800	142,600	120,600	104,500	92,200	87,100	82,500	78,400	
2 1/2	250,900	209,100	167,300	139,400	132,100	125,500	114,000	96,500	83,600	73,800	69,700	66,000	62,700	
3	209,100	174,200	139,400	116,200	110,000	104,500	95,000	80,400	69,700	61,500	58,100	55,000	52,300	
3 1/2	179,200	149,300	119,500	94,300	99,600	89,600	81,500	68,900	59,700	52,700	49,800	47,200	44,800	
4	156,800	130,700	104,500	87,100	82,500	78,400	71,300	60,300	52,300	46,100	43,600	41,300	39,200	
4 1/2	139,400	116,200	92,900	77,400	73,400	69,700	63,400	53,600	46,500	41,000	38,700	36,700	34,800	
5	125,500	104,500	83,600	69,700	66,000	62,700	57,000	48,300	41,800	36,900	34,800	33,000	31,400	
5 1/2	114,000	95,000	76,000	63,400	60,000	57,000	51,800	43,900	38,000	33,500	31,700	30,000	28,500	
6	104,500	87,100	69,700	58,100	55,000	52,300	47,500	40,200	34,800	30,700	29,000	27,500	26,100	
6 1/2	96,500	80,400	64,300	53,600	50,800	48,300	43,900	37,100	32,200	28,400	26,800	25,400	24,100	
7	89,600	74,700	59,700	49,800	47,200	44,800	40,700	34,500	29,900	26,400	24,900	23,600	22,400	
7 1/2	83,600	69,700	55,800	46,500	44,000	41,800	38,000	32,200	27,900	24,600	23,200	22,000	20,900	
8	78,400	65,300	52,300	43,600	41,300	39,200	35,600	30,200	26,100	23,100	21,800	20,600	19,600	
8 1/2	73,800	61,500	49,200	41,000	38,800	36,900	33,500	28,400	24,600	21,700	20,500	19,400	18,400	
9	69,700	58,100	46,500	38,700	36,700	34,800	31,700	26,800	23,200	20,500	19,400	18,300	17,400	
9 1/2	66,000	55,000	44,000	36,700	34,800	33,000	30,000	25,400	22,000	19,400	18,300	17,400	16,500	
10	62,700	52,300	41,800	34,800	33,000	31,400	28,500	24,100	20,900	18,400	17,400	16,500	15,700	
11	57,000	47,500	38,000	31,700	30,000	28,500	25,900	21,900	19,000	16,800	15,800	15,000	14,300	
12	52,300	43,600	34,800	29,000	27,500	26,100	23,800	20,100	17,400	15,400	14,500	13,800	13,100	
13	48,300	40,200	32,200	26,800	25,400	24,100	21,900	18,600	16,100	14,200	13,400	12,700	12,100	
14	44,800	37,300	29,900	24,900	23,600	22,400	20,400	17,200	14,900	13,200	12,400	11,800	11,200	
15	41,800	34,800	27,900	23,200	22,000	20,900	19,000	16,100	13,900	12,300	11,600	11,000	10,500	
16	39,200	32,700	26,100	21,800	20,600	19,600	17,800	15,100	13,100	11,500	10,900	10,300	9,800	
17	36,900	30,700	24,600	20,500	19,400	18,400	16,800	14,200	12,300	10,900	10,200	9,700	9,200	

SEED  
SPAC-  
ING  
(INCH-  
ES)

# VACUUM

## Standard Turbofan

The standard turbofan has a plastic impeller blade and is used on smaller planters. The standard turbofan has 3

PTO options 450, 540 or 1000 rpm. The standard turbofan can be equipped with a hydraulic drive option.

HS35416,0000D50 -19-25JUN19-1/1

## High Output Turbofan

The High Output Turbofan has the same housing as the Standard, but with an aluminum impeller blade, and is

used on medium sized planters. The high output turbofan has 2 PTO options 500 or 1000 rpm. The high output turbofan can be equipped with a hydraulic drive option. The high output turbofan requires a larger hydraulic motor.

HS35416,0000D51 -19-25JUN19-1/1

## Extra High Output Turbofan

The Extra High Output Turbofan has a larger aluminum impeller blade and a larger housing and is used on large planters. The Extra High Output Turbofan has 2 PTO options 540 or 1000 rpm. The Extra High Output Turbofan can be equipped with a hydraulic drive option. The Extra High Output Turbofan requires a larger hydraulic motor.

The vacuum hoses are attached to the inlet of the turbofan and deliver suction to the metering box of each row unit. An arrow decal on the turbofan housing indicates direction of impeller blade rotation. The top of the impeller blade will rotate towards the fan outlet. A protection shield against rain is located at the top of the turbofan, and when in an open position, indicates that the turbofan is operating.

HS35416,0000D52 -19-25JUN19-1/1

## Before Planting Checklist

- Make sure support strap hardware is tight
- Check all vacuum hoses for holes, tears, breaks or kinks
- Be sure vacuum gauge is functioning
- Inspect condition and tension of drive belt
- Grease U-Joints on PTO shafts
- Be sure top and bottom bearings spin freely
- Check condition of hydraulic hoses if equipped with hydraulic drive

### Tensioning Fan Belt with Belt Tension Bolt

See diagrams at right for PTO and Hydraulic drive

- Loosen 4 flange nuts (C) around lower bearing housing bracket.
- Loosen jam nut (B).
- For a Standard Turbofan torque bolt (A) to 6 ft-lbs.
- For High Output and Extra High Output Turbofans torque bolt (A) to 13 ft-lbs.
- Tighten jam nut (B) and 4 flange nuts (C) around lower bearing housing bracket.

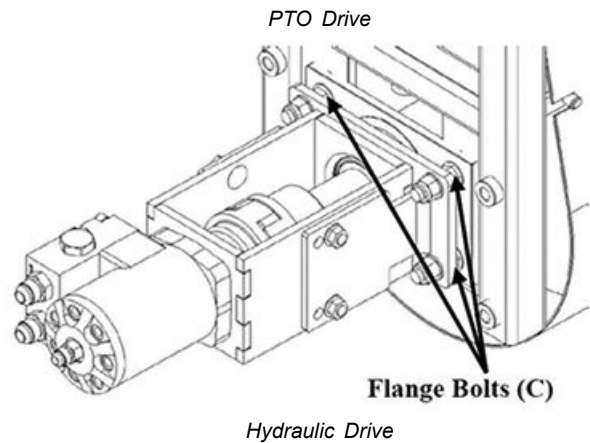
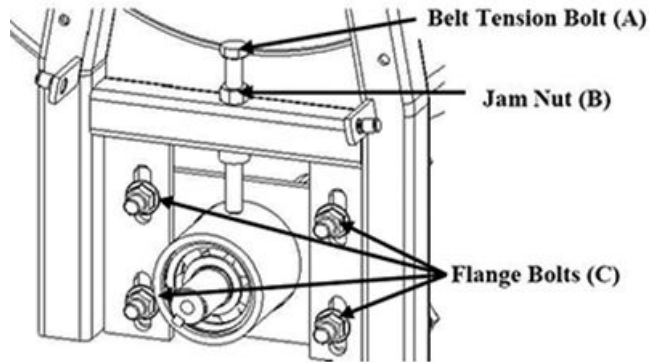

Continued on next page

HS35416,0000D53 -19-25JUN19-1/4

APY18001—UN—05MAR19

APY18002—UN—05MAR19

**PTO (Power Take Off)**

The PTO connects the tractor to the turbofan.

Make sure you connect the proper end of the PTO to the tractor. An arrow on the PTO indicates the end that is attached to the tractor.

The following warning is placed on your PTO shaft for your safety.

**DANGER** Rotating drive line contact can cause death – keep away. Do not operate without all drive-line, tractor and equipment shields in place, without drive-lines securely attached at both ends, and without drive-line shields that turn freely on drive-line.

**Hydraulic Drive**

**Hydraulic Drive Optional for 450 Standard, 500 High Output, or 540 Extra High Output Turbofans**

Hydraulic drive is optional for the 450 Standard turbofan, 500 High Output turbofan, and 540 Extra High Output turbofan. The hydraulic drive attaches to the turbofan to produce and maintain the vacuum level.

The desired vacuum is dependent on the correct amount of oil flow to the hydraulic motor.

**Starving the motor of oil will cause the vacuum to drop. An excessive amount of oil flowing into the motor can result in damage to the motor or the turbofan.**

When attempting to shut off the turbofan, the blade must be allowed to "spin down". If the flow of oil stops abruptly, the check valve in the block on the motor will re-circulate the oil already in the motor helping to prevent damage to the fan and motor. Still, you should not allow the flow of oil to stop suddenly. You should move the remote running the fan to the float position when shutting down the hydraulic fan. Refer to your tractor's operators manual for further information.

**You can control oil flow to the motor in one of three ways:**

1. With the tractor hydraulic system controls. This is the most common and recommended method.
2. With a flow control valve (part number FN30SK) that is optional for the hydraulic motor. For closed-center tractor hydraulic systems only.
3. With a bypass flow control valve (part number 300954) that is optional for the hydraulic motor. For all open-center tractor hydraulic systems. Can be used with closed-center systems also.

Monosem hydraulic drives are closed center systems. Contact your Monosem dealer if you tractor has an open center hydraulic system.

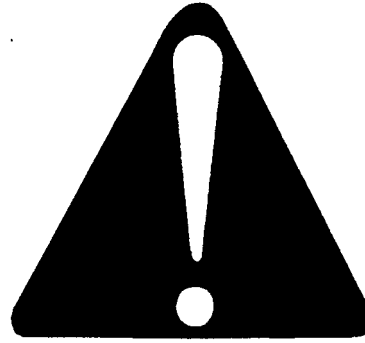

T81389 —UN—28JUN13

TS1644 —UN—22AUG95

Continued on next page

HS35416,0000D53 -19-25JUN19-2/4

**HYDRAULIC SYSTEM SAFETY DANGER.** Before applying pressure to the hydraulic system, check that all connections are tight and that the hoses and fittings have not been damaged. Hydraulic fluid escaping under pressure can penetrate the skin causing serious injury. If injured by escaping hydraulic fluid see a doctor at once. Gangrene can result.

- Relieve pressure on system before repairing, adjusting or disconnecting.



Continued on next page

HS35416,0000D53 -19-25JUN19-3/4

T81389 —UN—28JUN13

X9811 —UN—23AUG88

### Hydraulic Motor Case Drain

High Output and Extra High Output (and some Standard) fan motors are equipped with a case drain port. The case drain is plumbed into the back end of the motor, opposite the output shaft. The case drain allows excess heat and pressure to escape the body of the motor. The case drain is a flat faced coupler that plugs into a dedicated port on the tractor. This allows the oil to free flow directly to the tractor's hydraulic oil reservoir. If case drain line port is capped off this may result in damage to the motor's shaft seal.

Refer to your tractor's manual or contact your dealer for further information on the tractor drain kit.

When uncoupled, the coupler has a 10psi relief pressure.

#### Hydraulic flow requirements are as follows:

- **Standard turbofans: 6-7 gal/ minute**
- **High output & Extra high output turbofans: 10-11 gal/minute**

*NOTE: Check the labeling on your turbofan to determine if you have a standard, high output or extra high output turbofan. As a general rule, planters with 8-15 rows have a high output turbofan, 16-rows and larger use an extra high output turbofan.*

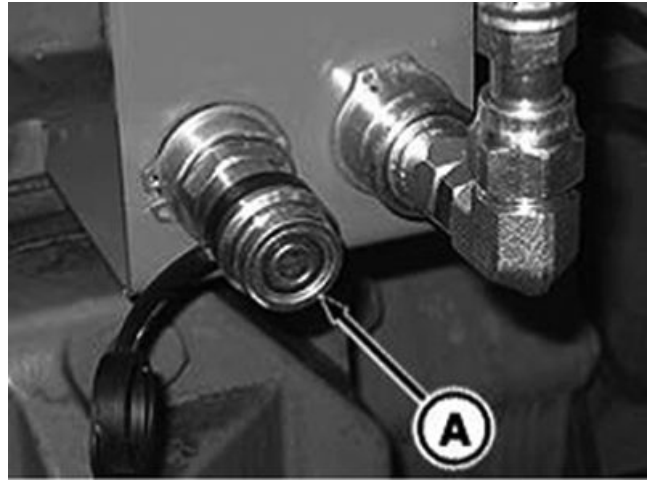

Tractor Side Female Drain Port (A)

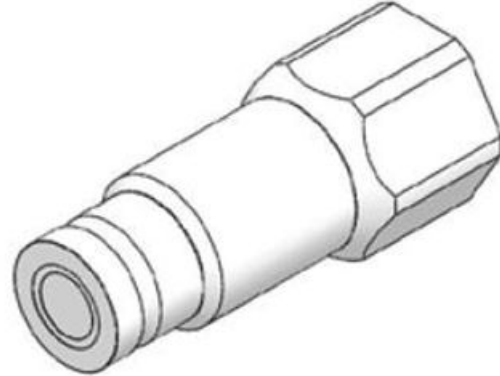

Planter Side Male Case Drain Coupler

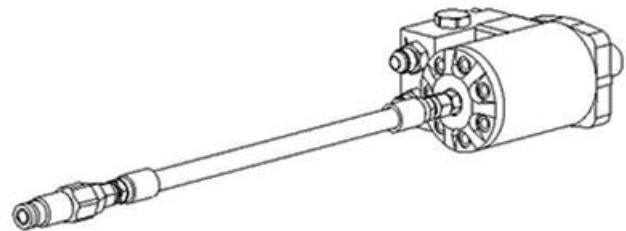

Case Drain Setup

APY18003—UN—05MAR19

APY18004—UN—05MAR19

APY18005—UN—05MAR19

HS35416,0000D53 -19-25JUN19-4/4



### Vacuum Gauge Settings

All Monosem planters are equipped with a vacuum gauge that allows you to read the vacuum level of the turbofan. The vacuum level should be set depending on the weight and size of the seed to be planted. Planters with 2 turbofans may be equipped with 2 vacuum gauges. Vacuum gauge settings are shown below in inches of water column.

Seeds Size	Seeds Examples	Vacuum Gauge Setting (inches of water column)
Small Seeds	Sugarbeet, Pickle, Canola, Cabbage, Collard Greens	15"-20"
Medium Seeds	Corn, Soybeans, Cotton, Pumpkin, Squash	20"-25"
Large Seeds	Kidney Beans, Fava Beans, Peanuts	25"-30"

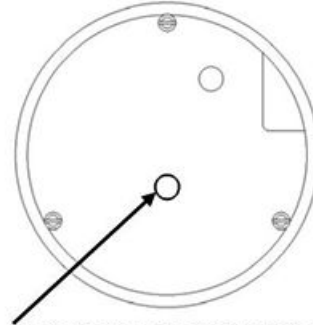

Center hole on back is used for vacuum or a vented plug. Top hole is plugged

HS35416,0000D54 -19-25JUN19-1/2

APY18006 —UN—05MAR19

APY18007 —UN—05MAR19

### To set the vacuum level for PTO and Hydraulic drive:

It is not necessary to have to reset vacuum levels daily. Vacuum levels will be slightly lower during tractor and pump start-up.

1. Use the recommended vacuum settings above, or consult your Monosem dealer.
2. Engage PTO or push tractor lever/switch to start oil flow to hydraulically driven turbofan and let oil warm up.
3. With some seed in the hoppers, turn drive wheels by hand or lower planter to engage drive wheels and drive forward a short distance to fill cells on seed discs with seed. This will result in the most accurate setting for the vacuum.
4. Re-adjust the PTO speed or oil flow, if necessary, until the desired vacuum level is obtained on the vacuum gauge.

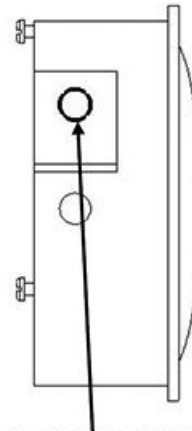

Top hole on the side used for vacuum or vented plug, bottom hole is plugged

HS35416,0000D54 -19-25JUN19-2/2

APY18008 —UN—05MAR19

# ROW UNIT

## NG Plus 4 Row Unit

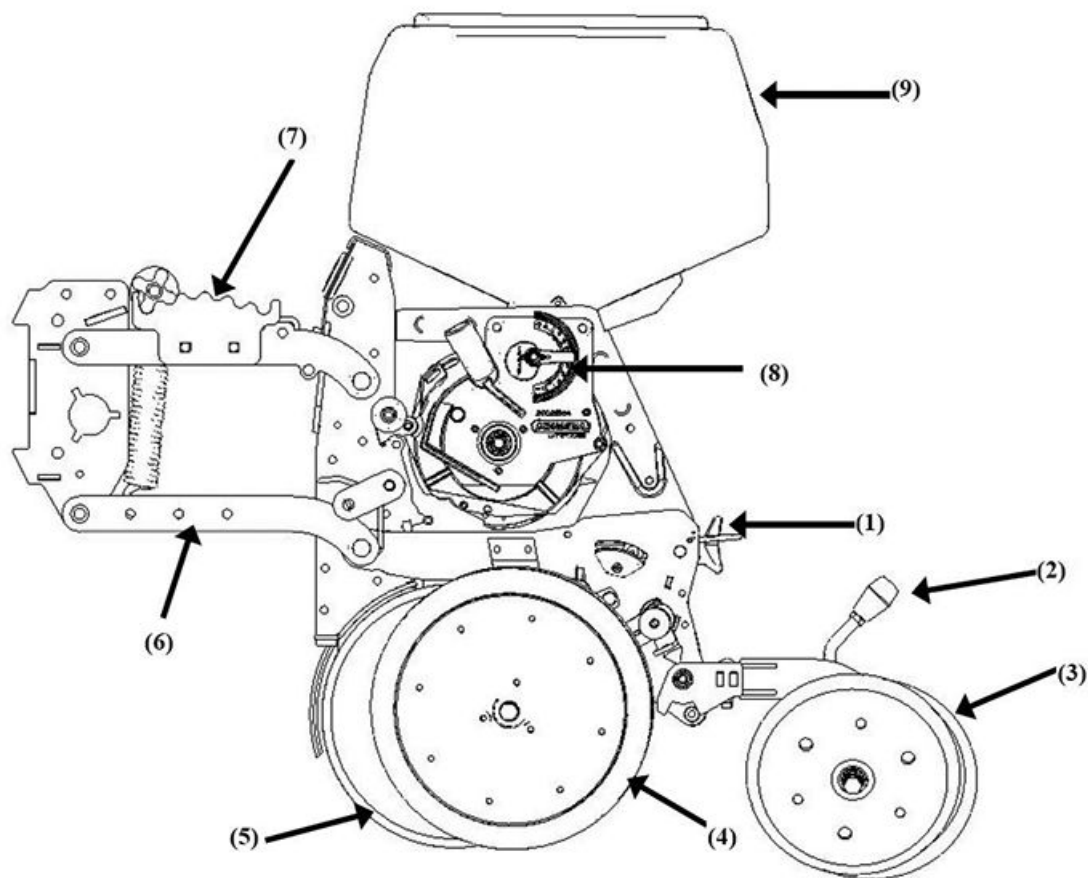

*NG Plus 4 Row Unit*

- |                                |                              |                                 |
|--------------------------------|------------------------------|---------------------------------|
| (1)— Depth Adjustment Knob     | (4)— Independent Gauge       | (7)— Quick Adjust Down Pressure |
| (2)— Lever for Closing Wheel   | (5)— Heavy Duty Disc Openers | (8)— Metering Box               |
| (3)— Adjustable V Press Wheels | (6)— Common Narrow Linkage   | (9)— 2 Bushel Plastic Hopper    |

The NG Plus 4 row unit is shown above with standard features. Other options are available for specific conditions or uses.

HS35416.0000D55 -19-25JUN19-1/1

APY18009 —UN—05MAR19

### Seed Depth Adjustment

Adjust the seed depth by turning the knob(A). Turning the knob changes the height of the depth gauge wheels in relation to the disc openers. One full revolution of the adjustment knob (A) is equal to approximately 1/8th inch of adjustment. A depth gauge on both sides of the unit (B), indicates the set depth. Seed depth ranges is from 1/8" to 3" deep. Be sure to set all of the row units on the planter at the same adjustment. Set a depth that is best suited for your soil conditions.

### Depth Gauge Wheels

The depth gauge wheels use an equalizing rocker arm to achieve uniform depth control of the disc openers. The gauge wheels are independent of each other for a consistent ride through the field.

In order for the disc openers to remain properly clean and free of soil build-up, make sure the flange of the gauge wheel is just touching the disc. To double-check this, raise the unit and manually rotate disc openers the gauge wheels should also rotate freely without restriction.

Adjust gauge wheel spacing by moving the washers from one side of the articulating arm to the other. Use a high quality SAE grease to lubricate the gauge wheel arms. Gauge wheel arms should be greased daily, more often in extreme conditions.

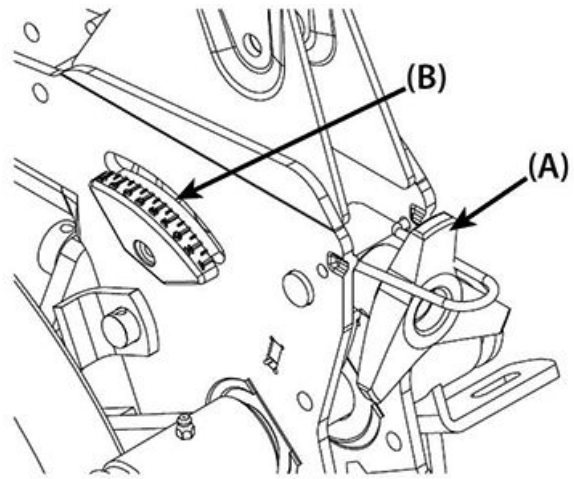

APY18012 —UN—19JUN19

### Drive Chain

The drive chains have a spring-loaded tensioner. The chain may need to shorten or replace the chain if wear stretches the chain and reduces spring tension.

Periodically check the pivot point of the chain idlers to ensure they rotate freely. Use a chain lubricant spray daily, or as needed. Dry moly is the recommended chain lubricant.

HS35416,0000D56 -19-25JUN19-1/1

### Double Disc Openers

#### Double Disc Openers

The heavy-duty double disc openers are very durable and mounted on sealed roller bearings. Their function is to slice the soil, and open a straight seed trench. An interchangeable firming point attached to the frame and positioned ahead of the seed tube also acts as an inner disc scraper.

A disc scraper is mounted to the outside of each disc. Adjust the pressure of the scrapers by tightening or loosening the bolts.

#### Checking Pinch Point

The double disc openers should have a pinch point length between 1.5" to 2.25". The pinch point is adjusted by

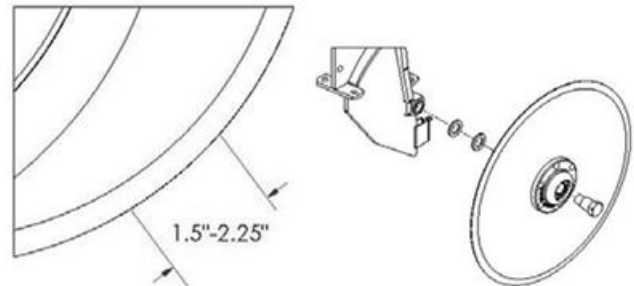

adding or removing shims to the spindle bolt. The spindle bolts should be torqued to 100 ft-lbs.

HS35416,0000D57 -19-25JUN19-1/1

APY18010 —UN—05MAR19

### Replacing Double Discs

The double disc openers need replaced when the disc diameter measures 14.5" or less, or a 1.5" pinch point cannot be achieved.

HS35416,0000D58 -19-25JUN19-1/1

## V Press Wheels

### V Press Wheels

The V Press Wheels affect only the closing of the seed furrow. Adjust pressure by moving the adjustment handle rearward to increase and forward to decrease pressure. This adjustment allows for shallow (beet), medium (corn) or deep (bean) planting. Choose the pressure best suited for your soil conditions and seed type. Shims are provided on each wheel axle to allow adjustment in the gap between wheels. Adjust as needed for seed depth and soil conditions.

Other closing systems are available. Contact your Monosem dealer for more information.

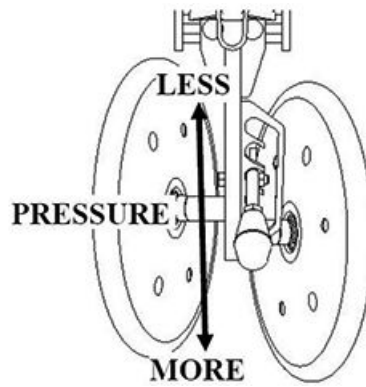

APY18011 —UN—05MAR19

Continued on next page

HS35416,0000D59 -19-25JUN19-1/2

- **Standard Disc Closing Wheels**  
(If Equipped) To adjust the disc flat press wheel pressure turn knob (A) clockwise to increase pressure and counterclockwise to decrease pressure. Turn knob (B) clockwise to decrease aggressiveness of discs and counter clock wise to increase aggressiveness of discs.
- **Twin Row Disc Closing Wheel**  
(If Equipped) To adjust the flat press wheel pressure turn knob (A) clockwise to increase pressure and counterclockwise to decrease pressure. To adjust depth of closing discs loosen nuts (B) and slide disc mount brackets up or down. To adjust the angle of the discs loosen nut (C) and turn discs.

A—Knob

B—Knob

A—Knob

B—Nuts, To Adjust Depth of Closing Disc

C—Nuts, To Adjust Angle of Disc

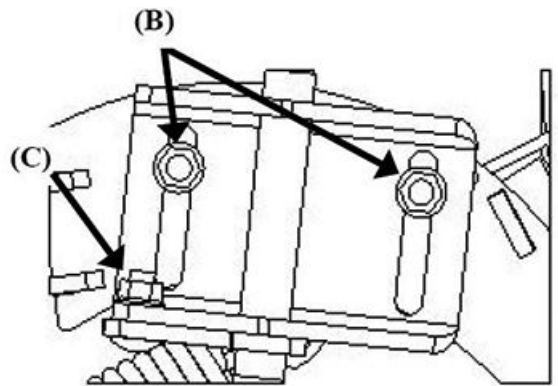
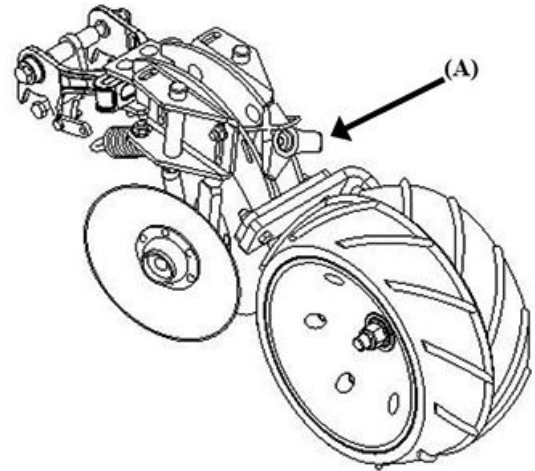
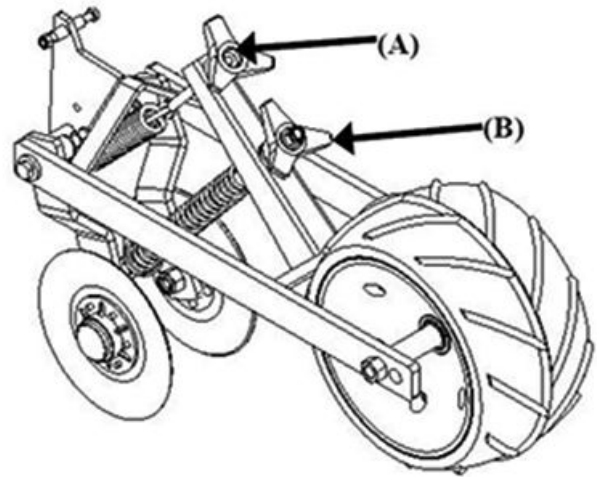

HS35416,0000D59 -19-25JUN19-2/2

APY18034 —UN—19JUN19

APY18013 —UN—05MAR19

APY18014 —UN—05MAR19

## Seed Hopper

A 2 bushel hopper with lid is standard on the NG+ 4 unit.  
3 bushel hoppers are optional.

HS35416,0000D5A -19-25JUN19-1/1

### Standard Down Pressure Springs

The Down Pressure springs located within the parallel linkage apply down force to maintain proper ground engagement. To achieve best performance from the row unit the parallel linkage should run parallel to the ground. Failure to run the linkage parallel with the ground can cause **irregular seed depth, poor singulation, poor seed spacing, and poor closing of the seed trench.**

Quick-Adjust Springs, Monoshox® and Monoshox®Air are down pressure options. Contact your Monosem dealer for more information.

#### Down Pressure Settings

Adjust tension bolt (A) to extend spring (B) to achieve desired down pressure. Once set, tighten nut (C) to lock setting. Measure distance (D) between bracket and top of spring to set all rows with equal down pressure.

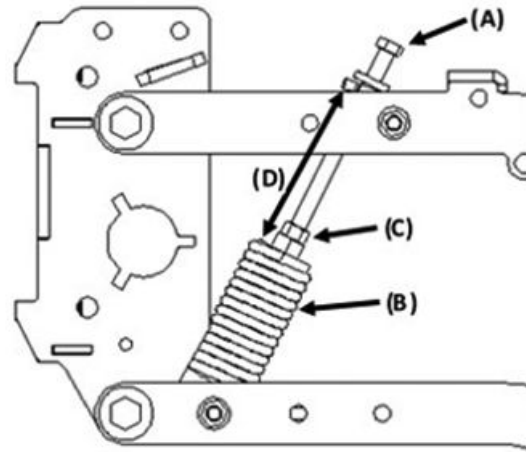

APY18032 —UN—28MAY19

HS35416,0000D5B -19-25JUN19-1/1

### Seed Meter

The seed metering system is made of cast aluminum and consists of two parts, the **main housing**, and the removable **cover**. The metering box is equipped with a stainless steel seed disc that delivers the seed to the seed tube.

*NOTE: No seed lubricant is needed for the Monosem meter. However, the use of talc is recommended for machines with Central Seed System (CSS). CSS systems use mini hoppers.*

#### Meterbox Main Housing

The main housing is mounted in the planter unit frame. Components in the main housing are the plastic wear gasket (1), cap plate (2), seed disc (not shown), and seed scraper (3). A vacuum seal is made between the seed disc and the plastic gasket. Make sure the plastic gasket piece is smooth and free of any defects. Under normal operating conditions, replace the gasket when the wear indicator (4) is less than .5 mm or .0196 in. deep.

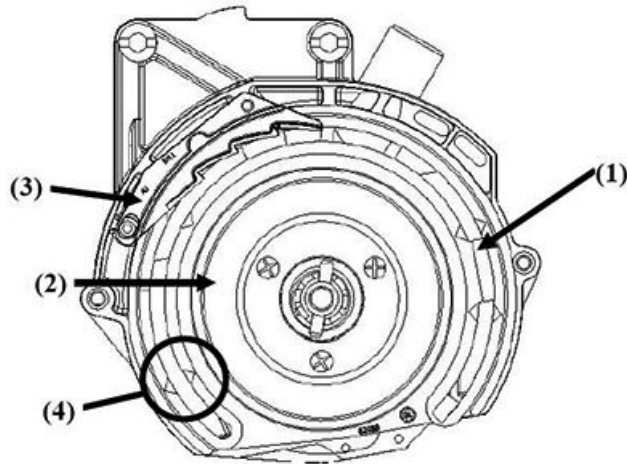

Meterbox Main Housing

- 1— Plastic Wear Gasket
- 2— Cap Plate
- 3— Seed Scraper
- 4— Wear Indicator

APY18016 —UN—05MAR19

Continued on next page

HS35416,0000D5C -19-25JUN19-1/9

### Changing Meter Bearings

Remove the lynch pin (1) and sprocket (1) from the shaft. Remove the snap rings (2), (3) on either side of the shaft. Pull the shaft (4) out the open side of the meter. Remove the bearings (5) from the meter. Before installing new bearings clean the inside of the housing for the bearings to make sure the new bearings fit properly.

- |                           |             |
|---------------------------|-------------|
| 1— Lynch Pin and Sprocket | 4— Shaft    |
| 2— Snap Ring              | 5— Bearings |
| 3— Snap Ring              |             |

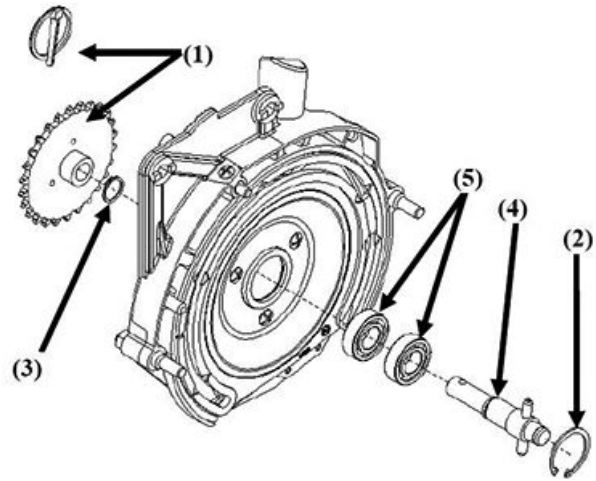

HS35416,0000D5C -19-25JUN19-2/9

APY18017—UN—05MAR19

### Replacing the Wear Gasket

To replace the gasket remove the three bolts (4) holding the cap plate (3) in place. Next remove the old gasket by pulling out at the bottom center of the gasket. Once gasket is removed thoroughly clean the perimeter groove and inside of the meter to remove any build up or debris. Ensure that the metal brace (1) is in good condition, replace if bent. To install the new gasket rotate the outer edge of the plastic wear gasket (2) into the groove. It will lock into place when the stub (2A) fits into the hole (2B) of the housing. Next install the cap plate (3) and three bolts and nuts (4).

*NOTE: Thoroughly clean the metering box housing before installing a new wear gasket. Any residue left from previous use will not allow the gasket to fit properly and cause vacuum leaks.*

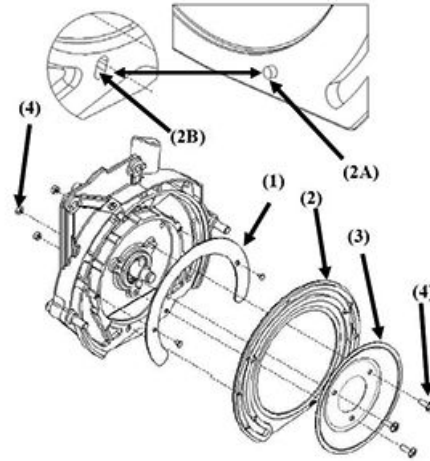

- |                |              |
|----------------|--------------|
| 1— Metal Brace | 2B—Hole      |
| 2— Wear Gasket | 3— Cap Plate |
| 2A— Stub       | 4— Bolts     |

### Adjusting Singulator

On the outside of the main housing is the lever (1) for adjusting the air suction in relation to the weight of the seed. This lever also sets the height of the seed scraper.

**By turning the outside lever, (1) , two adjustments are made at the same time:**

- **Adjustment One-** The lever adjusts the height of the scraper in relationship to the holes in the seed disc.

- **Adjustment Two-** At the same time it adjusts the air suction (from the turbofan) to the weight of the seed.

Continued on next page

HS35416,0000D5C -19-25JUN19-3/9

APY18018—UN—05MAR19

**For Larger Seed, to Increase Suction**

• **+0 to +5**

When the indicator (1) is moved toward plus, “+”: the scraper moves away from the holes of the seed disc and closes the size of the hole on side of the meterbox (2). This increases the suction, and may cause doubles if the indicator is raised too high.

• **0 to -5**

When the indicator (1) is moved toward minus, “-”: the scraper moves towards the holes of the seed disc and opens the hole on the side of the meterbox (2). This decreases the suction, and may cause skipping if the indicator is too low.

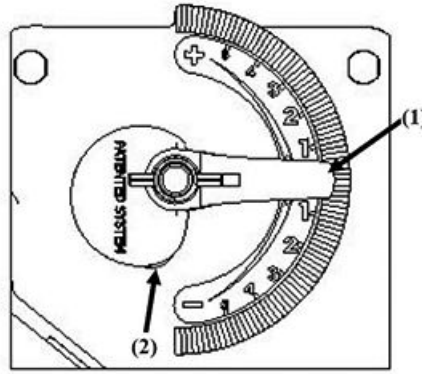

1— Indicator

2— Hole

The clear plastic control window on the cover allows monitoring of seeds on disc.

HS35416.0000D5C -19-25JUN19-4/9

APY18019 —UN—05MAR19

**Setting for LARGER SEED the hole on meter-box closes, which increases suction and the SCRAPER moves away from the seed disc hole.**

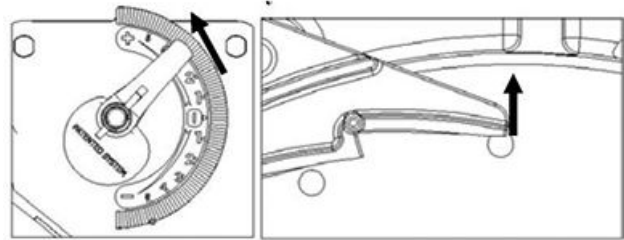

Continued on next page

HS35416.0000D5C -19-25JUN19-5/9

APY18020 —UN—05MAR19



**Setting for SMALLER SEED** the hole on meter-box opens which reduces suction and the **SCRAPER** moves towards the seed disc hole.

See “**Vacuum Fan**” for Turbofan vacuum settings.

Recommended Settings for the Indicator:	
Peanuts	+4 ½ (+4 to +5)
Edible Beans	+3 to +5
Sorghum/ Milo	+3
Soybeans/ Peas	+2 to +4
Cabbage	+2
Sugarbeet	+2
Corn	+1 (0 to +2)
Sunflowers	+1 (0 to +2)
Cotton	+1
Canola	0 to +1
Pickle/ Melon	-1 ½ (-1 to -2)
Hemp	0 to +1

*NOTE: The above settings are base lines settings, so checking before and during planting is essential.*

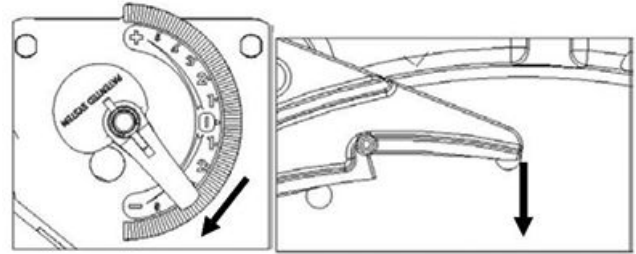

APY18021—UN—05MAR19

HS35416,0000D5C -19-25JUN19-6/9

**Meterbox Cover**

The cover is the removable part of the metering box. Two wing nuts secure the cover to the main housing. The components on the outside of the cover are a control window and trap door. The components on the inside of the cover are a metal shutter and ejector block. Use a special cover for extra large seed such as peanuts and kidney beans. See **EXTRA LARGE SEED** for more information.

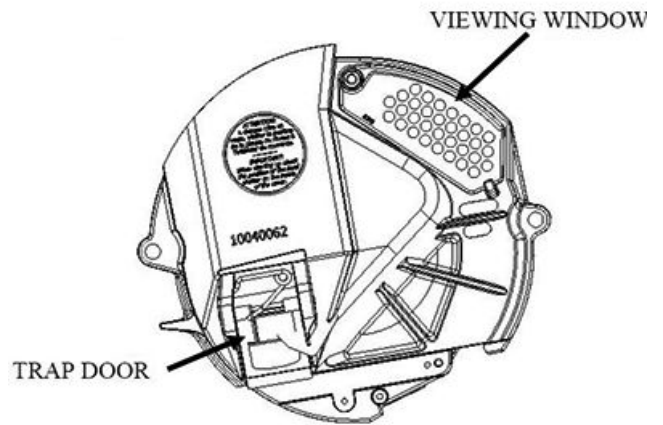

Meterbox Cover

APY18022—UN—05MAR19

Continued on next page

HS35416,0000D5C -19-25JUN19-7/9

### Interior Shutter Adjustment

The metal shutter inside the cover regulates the flow of seeds coming from the hopper and provides a constant and sufficient level of seed in front of the disc.

Adjust the interior shutter by loosening two bolts (1) and then lowering the shutter. A small plastic sheet is located under the shutter. The shutter limits the level of seeds in front of the disc.

**High Position: For Large Seeds**, such as corn, soybean, edible beans, cotton, etc. The high position moves the shutter away from the opening.

**Low Position: For Small Seeds**, such as sugar beet and milo. The low position moves the shutter over part of the opening.

The brass ejector block (2) knocks seed off the planting disc directly above the seed tube. Periodically check the ejector block for wear and assure it has free movement.

### Extra Large Seed

A special metering box cover is used for seeds such as peanuts, and kidney beans. This special metering box cover has a larger opening (to improve the seed flow into the seed chamber), a larger discharge channel (to avoid blockage), and a special less aggressive seed scraper (to avoid skips). The metal shutter should be in the "**high position**" for these large seeds.

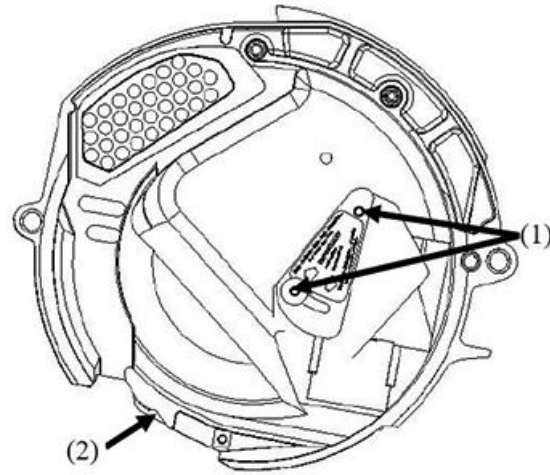

1— Bolts

2— Brass Ejector Block

*NOTE: The large cover can be used for smaller seed sized crops. To use the large seed cover with small seed, adjust the metal shutter to a low position and add a special bolt-on plastic restrictor.*

HS35416.0000D5C -19-25JUN19-8/9

APY18023 —UN—05MAR19

### Disengaging the Metering Box

To disengage a row unit remove the lynch pin in the sprocket on the main housing, (1) and/or disconnect the vacuum hose from the meterbox (2).

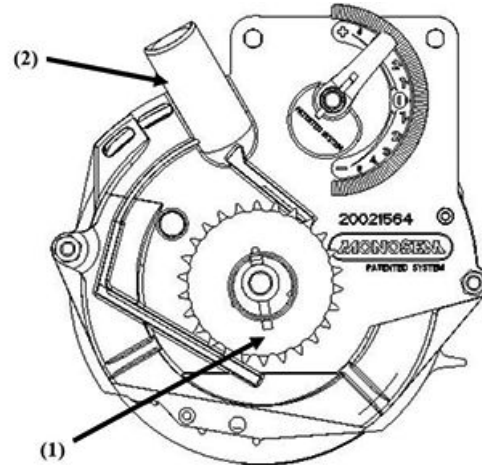

HS35416.0000D5C -19-25JUN19-9/9

APY18024 —UN—05MAR19

### Seed Tube

Before and during each new planting season, inspect seed tubes for damage to ensure consistent and regular seeding.

**To replace the seed tube**, remove the metering box cover and seed disc to remove the top pin holding the

tube in place OR remove the metering box cover and the seed disc.

In dusty conditions periodically run a brush through the seed tube to clean the sensor eye.

HS35416.0000D5D -19-25JUN19-1/1

### Seed Chute

The seed chute simplifies the job of emptying the hoppers. Attach the chute (1) to the Row Unit. Place a bucket at the bottom of the chute, lift the seed chute door and collect the left over seed.

1— Chute

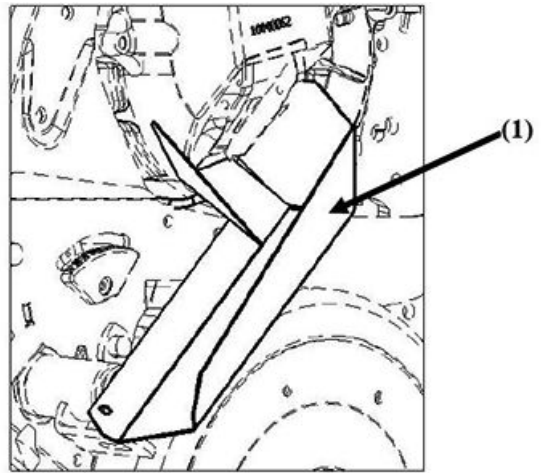

Seed Chute

HS35416,0000D5E -19-25JUN19-1/1

APY18025—UN—05MAR19

### Seed Disc

Use the proper seed disc for different seeds. Check your type of seed, and use the **Seed Disc Recommendations** chart to determine the correct disc for your crop.

It is important to use seed discs that are clean and in good condition. Customized seed discs are not shown, but are available upon special request. It is not recommended to drill out seed discs. Any slight burrs or imperfections in drilling will alter the metering. Do not clean plugged holes with sharp metal objects. The precision of the seed discs must be maintained to have proper metering.

The brass agitator is secured to the seed disc with 6 special screws.

If/when seed discs are removed from the metering box to clean them or to use a different disc, use a permanent marker to identify which seed disc came from which metering box. Put seed discs back into their corresponding metering box. This assures wear patterns on the disc and gasket match to keep a proper vacuum seal.

### Seed Disc Identification

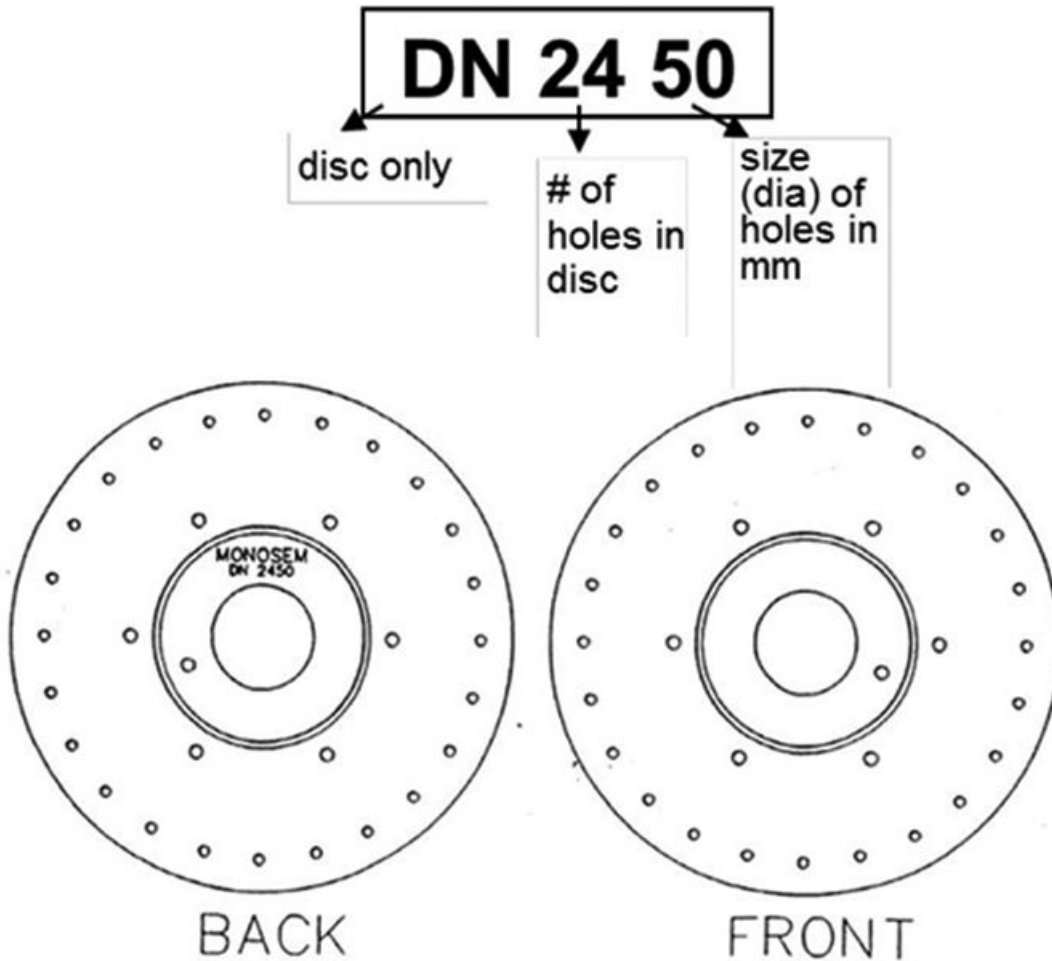

The size of the seed disc is engraved on the back of the seed disc. When ordering seed discs, the prefix DN indicates the disc only. The prefix DC indicates the complete disc with brass agitator (6212.a). The first two numbers of a four number series indicates the number of holes in the seed disc. The second two numbers indicates the size (diameter) of the holes.

#### Example:

**Seed Disc #DN 2450**

**DN** indicates disc only (no agitator)

**24** indicates 24 holes

**50** indicates the holes diameter 5.0 mm

08	0.8 mm
10	1.0 mm
12	1.2 mm
20	2.0 mm
35	3.5 mm
45	4.5 mm
50	5.0 mm
60	6.0 mm
65	6.5 mm

APY-18027 —UN—05MAR19

**Seed Disc Recommendations**

Crop	Seed Disc	Seed Examples	Seed Spacing
Beans	DC3665	Kidney Large, Pinto, Romano, Lima, Chicapee	2 3/8 - 7"
	DC4850		1 3/4 - 5 1/2"
	DC6045	Medium Seeds: Snap, Baby Limas, Soybeans	1 3/8 - 4 3/8"
	DC6035	Small Seeds: Navy, Peas	1 3/8 - 4 3/8"
Broccoli and Cabbage	DC3612 (low population)	-	2 3/8 - 7"
	DC7212 (high population)	-	1 3/16 - 3 1/2"
Canola	DC7210 (Low Population)	Regular Coated Seed	1 3/16 - 3 1/2"
	DC7212 (Low Population)	Large Coated Seed	1 3/16 - 3 1/2"
	DC12010 (High Population)	Regular Coated Seed	1/2 - 2 1/4"
	DC12012 (High Population)	Large Coated Seed	1/2 - 2 1/4"
Cauliflower	DC3612 (low population)	-	2 3/8 - 7"
	DC7212 (high population)	-	1 3/16 - 3 1/2"
Collard Greens	DC7208, DC7210	-	1 3/16 - 3 1/2"
Corn	DC0950	Field	9 1/2 - 28"
	DC1250		7 - 21"
	DC1850 (low population)		4 3/4 - 14"
	DC2450 (medium population)		3 1/2 - 10 1/2"
	DC3050 (high population)		2 3/4 - 8 1/2"
	DC2437, small, 2700-5000 seeds/lb	Sweet	3 1/2 - 10 1/2"
	DC2445, large, 1700-2700 seeds/lb		3 1/2 - 10 1/2"
	DC2425	Ornamental	3 1/2 - 10 1/2"
Cotton	DC3635 (low population)	Single seed drop	2 3/8 - 7"
	DC6035 (high population)	Single seed drop	1 3/8 - 4 3/8"
	DC0930D (double seed drop)	Hill drop(seeds 3/4 - 2" apart)	9 1/2 - 28"
	DC0930T (triple seed drop)	Hill drop(seeds 3/4 - 2" apart)	9 1/2 - 28"
	DC1230D (double seed drop)	Hill drop(seeds 3/4 - 2" apart)	7 1/8 - 21"
	DC1230T (triple seed drop)	Hill drop(seeds 3/4 - 2" apart)	7 1/8 - 21"
	DC1830D (double seed drop)	Hill drop(seeds 3/4 - 2" apart)	4 3/4 - 14"
	DC1830T (triple seed drop)	Hill drop(seeds 3/4 - 2" apart)	4 3/4 - 14"
Cucumbers/ Pickles	DC1820	Hand harvest	4 3/4 - 14"
	DC3020	Machine harvest	2 3/4 - 8 1/2"
Hemp	DC0320	-	28 1/2 - 84"
	DC0620	-	14 1/4 - 42"
Kale	DC7208	-	1 3/16 - 3 1/2"
Melons	DC0620 (low population)	Watermelon, small seed, Cantaloupe	14 1/4 - 42"
	DC0920 (medium population)		9 1/2 - 28"
	DC1820 (high population)		4 3/4 - 14"
	DC0325 (low population)	Watermelon, large seed	28 1/2 - 84"
	DC0325D (hill drop )	Drop two seeds, 1-3/8 - 4-3/8" apart	28 1/2 - 84"
	DC0625 (medium population)	Drop two seeds, 1-3/8 - 4-3/8" apart	14 1/4 - 42"
	DC0625D (hill drop)		14 1/4 - 42"
	DC0925 (high population)		9 1/2 - 28"
Okra, Artichoke	DC3622	-	2 3/8 - 7"
	DC7222	-	1 3/16 - 3 1/2"
Onions	DC3610 (low population)	Raw	2 3/8 - 7"
	DC7210 (high population)		1 3/16 - 3 1/2"
	DC3622 (low population)	Pelleted	2 3/8 - 7"
	DC7222 (high population)		1 3/16 - 3 1/2"
Parsley	DC7208	-	1 3/16 - 3 1/2"

Continued on next page

HS35416,0000D5F -19-25JUN19-2/3

ROW UNIT

Crop	Seed Disc	Seed Examples	Seed Spacing
Peanuts	DC3665	Jumbo seed	2 3/8 - 7"
	DC3660 (twin row)	Small to medium seed	2 3/4 - 8 1/2"
	DC4060	Small to medium seed	2 1/8 - 6 1/2"
	DC4860(not recommended)	Small to medium seed, (High pop.)	1 3/4 - 5 1/2"
Peppers	DC3612 (low population)	-	2 3/8 - 7"
	DC7212 (high population)	-	1 3/16 - 3 1/2"
Pumpkins	DC0335 (low population)	-	28 1/2 - 84"
	DC0335D (hill drop)	Drop two seeds, 1-3/8 - 4-3/8" apart	28 1/2 - 84"
	DC0635 (medium population)	-	14 1/4 - 42"
	DC0635D (hill drop)	Drop two seeds, 1-3/8 - 4-3/8" apart	14 1/4 - 42"
	DC0935 (high population)	-	9 1/2 - 28"
Radish	DC6015	-	1 3/8 - 4 3/8"
Rice	DC9016	-	15/16 - 2 3/4"
Sesame	DC7208	-	1 3/16 - 3 1/2"
Sorghum	DC3622 (low population)	-	2 3/8 - 7"
	DC7222 (high population)	-	1 3/16 - 3 1/2"
Spinach	DC6015	Small seed	1 3/8 - 4 3/8"
	DC6020	Large seed	1 3/8 - 4 3/8"
	DC12020	Large seed(high populations)	11/16 - 2 1/16"
Squash	DC0625 (medium population)	Summer	14 1/4 - 42"
	DC0925 (high population)	-	9 1/2 - 28"
	DC0635 (medium population)	Winter	14 1/4 - 42"
	DC0935 (high population)	-	9 1/2 - 28"
Sugarbeets	DC4016 (medium population)	Small, Medium, Large & Pelleted seed	2 1/8 - 6 1/2"
	DC4020 (medium population)	Medium, Large and Pelleted seed	2 1/8 - 6 1/2"
	DC6020 (high population)	Medium, Large and Pelleted seed	1 3/8 - 4 3/8"
	DC12015 (seed production)	Small, Medium, Large & Pelleted seed	11/16 - 2 1/16"
	DC12020 (seed production)	Medium, Large and Pelleted seed	11/16 - 2 1/16"
Sunflowers	DC1225 (low population)	Oil & Confection	7 1/8 - 21"
	DC1825 (high population)	-	4 3/4 - 14"
Tomatoes	DC7212	-	1 3/16 - 3 1/2"
	DC1212T(hill drop 12 x 3 x 1.2)	-	7 - 21"
Turnips	DC7208	-	1 3/16 - 3 1/2"

HS35416,0000D5F -19-25JUN19-3/3

## Other Linkages

### Wide Linkage

Wide Linkage Down Pressure (2 Springs)	
1	232 lbs
2	288 lbs
3	310 lbs
4	335 lbs
5	410 lbs

Wide Linkage Down Pressure (4 Springs)	
1	310 lbs
2	358 lbs
3	400 lbs
4	475 lbs
5	535 lbs

*NOTE: Down pressure settings are approximate. Actual down pressure will vary depending on row unit options.*

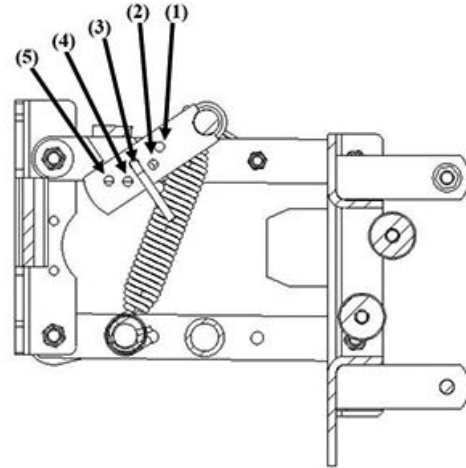
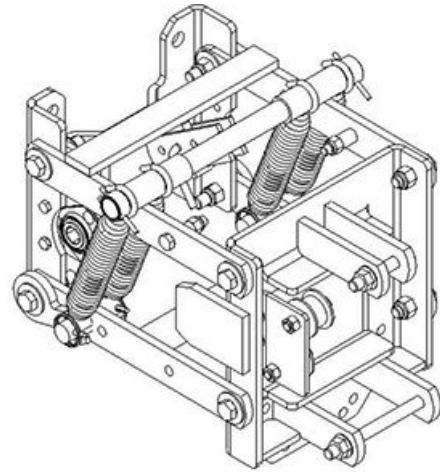

Wide Linkage Down Pressure

HS35416.0000D60 -19-25JUN19-1/1

APY18028—UN—05MAR19

APY18029—UN—05MAR19

## Metering Box Troubleshooting

### Problem: Excessive Skipping

#### Possible Reason:

Seed scraper is too low, Incorrect indicator setting.

Seed scraper is bent. (not flat)

The seed disc is bent or worn.

Seed scraper is dirty with chemical product.

Plastic wear surface gasket is warped or used up.

Holes of the seed disc are plugged (sugarbeets, rapeseed, cabbage.) Double-check from time to time.

The planter is working at an excessive speed.

Defective vacuum hoses.

The vacuum suction is insufficient.

Turbofan speed is too low.

Foreign material mixed with seed.

Seed blockage in the hopper, seed treatment product may be too moist.

Fan belt is too loose.

### Problem: Excessive Doubling

#### Possible Reason:

- Seed scraper is too high. Incorrect indicator setting
- Seed scraper is worn.
- The holes of the seed disc are too large for seed.
- Ground speed too fast.

### Problem: Skipping and Doubles

#### Possible Reason:

- Seed is bridging in the meterbox cover.
- Ground speed too fast.
- Holes of the seed disc are too large. (Cut off seeds)
- Fields are too steep.
- The shutter is adjusted incorrectly.
- Vacuum setting is too high.
- Seed Sensor eye is dirty.

### Problem: Irregular Spacing

#### Possible Reason:

- Ground speed too fast.
- Soil is sticking to the tires because it is too wet.
- Incorrect tire pressure.
- Seed level too low in the metering box, internal shutter not open enough.
- Ejector is damaged.
- Toolbar is not level.
- Contact drive is slipping.
- Meter bearings are bad.
- Damaged seed tube.
- Drive wheels not adjusted correctly.
- Chains not properly lubricated.
- Not enough down force, row unit not staying in the ground.
- Rubber boot interfering with seed drop at top of seed tube.

*NOTE: Toolbar must run level or slightly back.*

For 3pt Mounted Planters, make sure tractor is in "float" mode.

HS35416.0000D61 -19-25JUN19-1/1



# OPTIONS

## Quick- Adjust Down Pressure Springs

### Down Pressure Settings

1. 150 lbs
2. 225 lbs
3. 325 lbs
4. 400 lbs
5. 475 lbs

*NOTE: The above down pressures are approximate. Actual down pressure will vary depending on row unit options and seed level in the hopper.*

*NOTE: A 7/8" wrench is needed to adjust the down pressure.*

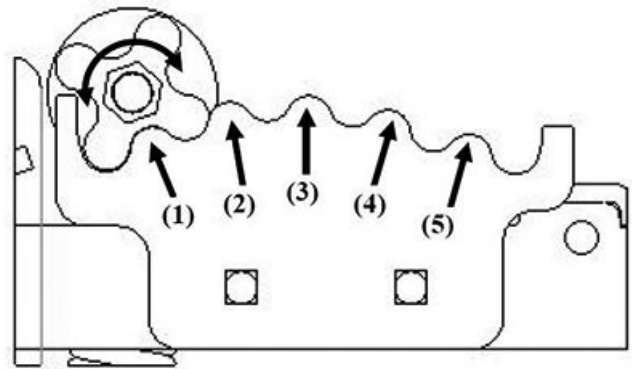

APY18015 —UN—05MAR19

HS35416,0000D62 -19-25JUN19-1/1

## Monoshox® Option

**⚠ CAUTION: MONOSHOX GAS SHOCK CONTENTS UNDER PRESSURE! USE EXTREME CAUTION! Do not attempt to pressurize or depressurize the shock.**

**⚠ CAUTION: FAILURE TO USE EXTREME CAUTION COULD RESULT IN SERIOUS INJURY OR DEATH!**

Do not replace the MONOSHOX® with other shocks or springs. Valving in the replacement shocks or springs may be different from the MONOSHOX, causing the row units to act differently.

### SPRING PRESSURE

Normal pre-load is when the compression nut (B) just touches the top of the spring. (No threads showing between compression nut and the top of spring). Base line down pressure for Monoshox is 275 lbs\*. Loosen the jam nut (A) and tighten the compression nut (B) above the spring with the supplied wrench to compress the spring. Each 1" of pre-load on the spring is equal to 55 pounds of down pressure.

\* This is an approximate down pressure, actual down pressure will vary based on row unit attachments and hopper level.

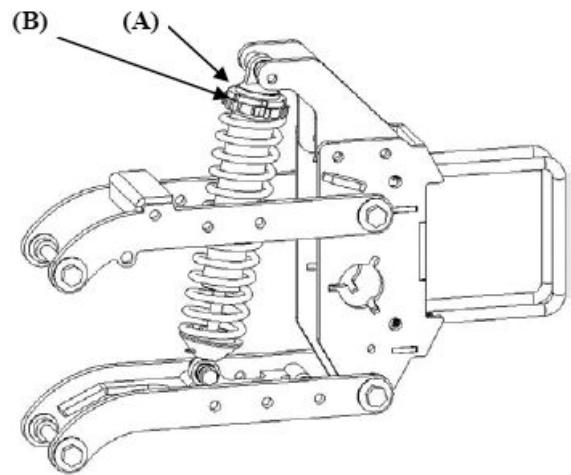

Monoshox Pictured

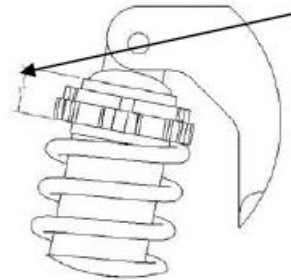

APY09731 —UN—20MAR19

APY09732 —UN—20MAR19

HS35416,0000D63 -19-25JUN19-1/1

### Monoshox®Air Option

MONOSHOX AIR	
AIRBAG PRESSURE (psi)	APPROXIMATE DOWNFORCE (lbs)
0	295
10	309
20	327
30	340
40	355
50	365
60	375
70	388
80	401
90	413
100	425

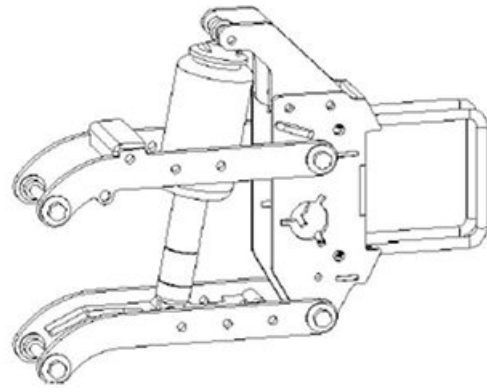

Monoshox Air Pictured

*NOTE: The values listed are average values, so individual readings can vary slightly +/- from those listed.*

HS35416,0000D64 -19-25JUN19-1/1

APY09730 —UN—22APR19

### Slotted Collar

The slotted collar stops the flow of seed to the meter. It is used in medium to large seed sizes.

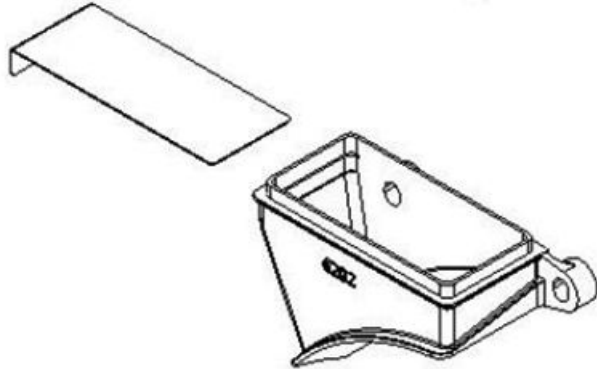

Slotted Collar

HS35416,0000D65 -19-25JUN19-1/1

APY18026 —UN—05MAR19

### Pro-Wheel Intermediate Press Wheel Option

The intermediate press wheel (Pro-Wheel) (A) is located in the lower rear of the unit body, behind the seed tube and between the gauge wheels.

The Pro-Wheel system consists of a large diameter cast aluminum wheel fitted with a stainless steel band. The Pro-Wheel is mounted in a spring-loaded pivoting bracket which allows it to float with the ground contour.

The Pro-Wheel runs in the seed trench to gently push the seed into the soil directly after exiting the seed tube. The Pro-Wheel insures excellent seed-to-soil contact.

#### Down Pressure Settings

The Pro-Wheel (A) down pressure is adjusted in combination with the closing wheel. Use handle (B) to increase/decrease down pressure of both Pro-Wheel and closing wheels.

*NOTE: If planter is equipped with other style of closing wheel, the down pressure of Pro-Wheel and closing wheel can be adjusted using the closing wheel bracket handle or knob.*

When not used, the Pro-Wheel can be rotated up and locked into raised position with locking tab (C).

Plastic scraper (D) is used to keep stainless steel band of Pro-Wheel clean. Scraper should be adjusted to maintain slight contact with wheel. Scraper can be turned over and flipped over to utilize all four corners for scraping edges before being replaced.

Tension of plastic scraper (D) to Pro-Wheel can be adjusted using spring-loaded nuts (E).

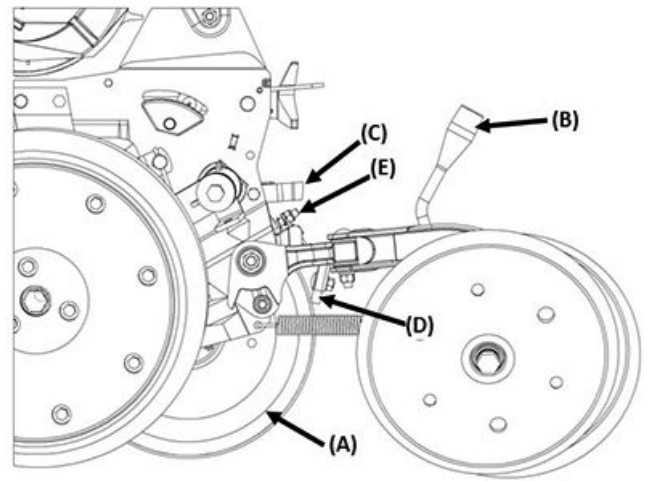

A—Pro-Wheel  
 B—Handle  
 C—Locking Tab  
 D—Plastic Scraper  
 E—Spring Loaded Nuts

*NOTE: Pro-Wheel is not intended for operation in wet or sticky conditions. If soil begins to adhere and accumulate on the Pro-Wheel, seed placement can be negatively affected.*

*For planting in wet or sticky conditions, Pro-Wheel should be locked up or removed.*

APY18033—UN—28MAY19

HS35416,0000D66 -19-25JUN19-1/1

## Sync-Row® System

### Sync-Row for MONOSEM Twin-Row

#### Setting the Twin-Row Stagger

Monosem Twin-Row planters with an adjustable sprocket require presetting each twin-row pair to produce the desired staggered, zigzag pattern. Presetting adjustments should be made during initial setup of the planter, or whenever seed spacing distance is changed, or when seed plates are changed to a different number of cells. Steps 1 through 6 are listed below as instructions for using the adjustable sprocket to adjust the twin-row meter mechanically.

#### QUICK LIST FOR ADJUSTABLE SPROCKET FOR TIMING

1. Lower Planter Units, Turn Off Tractor Engine.
2. Determine Row Planting Information.
  - Seed Spacing.
  - Left-Hand Row Offset Distance.
  - Number of Cells in Seed Disk.
3. Determine Ideal Row Adjustment Number.
  - On Chart From Above Information.
4. Check Calibration.
  - Check Calibration of Adjustable Sprocket's Zero-line. (See Calibration Section in Operator's Manual)
5. Adjust Individual Twin-Rows.
  - Align Magnet with Black Zero-Line.
  - Turn Front Disk to Align with Chart Number.
  - Reinstall Lynch Pin.
  - Repeat for Each Row.
6. Check Twin-Rows for Accurate Stagger.

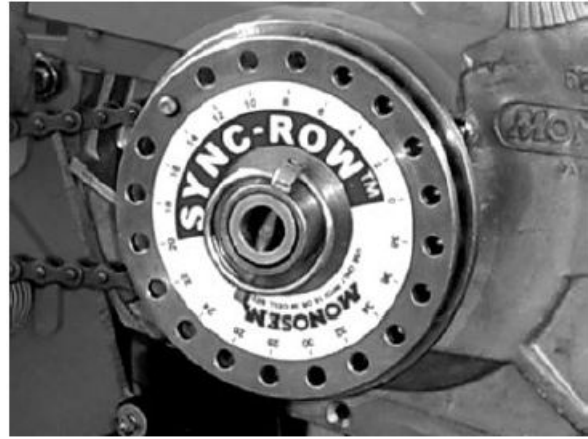

Sync Row

APY09733 —UN—20MAR19

#### INSTRUCTIONS AND ADJUSTMENTS

##### For Adjustable Metering Sprocket

1. TURN OFF TRACTOR ENGINE, LOWER PLANTER UNITS

**IMPORTANT: Failure to follow this instruction can result in being trapped beneath machinery and cause serious injury or death.**

Before making any adjustments on the planter row units for Twin-Row staggered seed placement, lower the planter frame and units to the ground or install hydraulic ram safety stops, engage the tractor's parking brake, and turn off engine power. Follow this step whenever making adjustments or readjustments.

Continued on next page

HS35416,0000D67 -19-25JUN19-1/6

2. DETERMINE ROW PLANTING INFO

Determine for each Twin-Row pair:

- What seed spacing you will be planting
- Number of seed plate cells (holes) used in the seed meter

Insure that the seed spacing you select is correct by averaging the measured distance of several planted seeds. Discrepancies can occur between theoretical (chart) distances from the owners manual and the actual planted distance due to soil type, planting speed, etc. If this does occur, use the measured seed spacing value.

3. DETERMINE CHART NUMBER

For each Twin-Row pair use the SYNC-ROW TIMING CHART on page 1. that corresponds with your Row spacing to determine the ideal row adjustment number (chart number.) Use the row planting information determined in Step 2. to base your adjustment number on. When looking at the average seed distance, use the chart value closest to the actual value determined in Step 2. If you wish to plant a seed spacing that is not listed in the chart provided, contact your Monosem Dealer.

4. CHECK CALIBRATION

The adjustable sprocket has a black zero-line that indicates where the "zero" on the magnetic decal should align. This is done at the factory. This will not change, unless a sprocket or part of the adjustable sprocket is replaced on one of the Twin-Row units in the pair. If a part or sprocket is replaced, go through section at the end of these instructions, "CALIBRATE ADJUSTABLE SPROCKET" before continuing with Step 5.

5. ADJUST SPROCKET

Repeat Step 5. for each Twin-Row pair.

- A - The adjustable sprocket should have a zero-line (A) where the "zero" on the magnetic decal (B) should be aligned. The placement of this line is established in the calibration of the adjustable sprocket (See Step 4). Make sure the decal is aligned properly with the zero-line and remove the lynch pin.

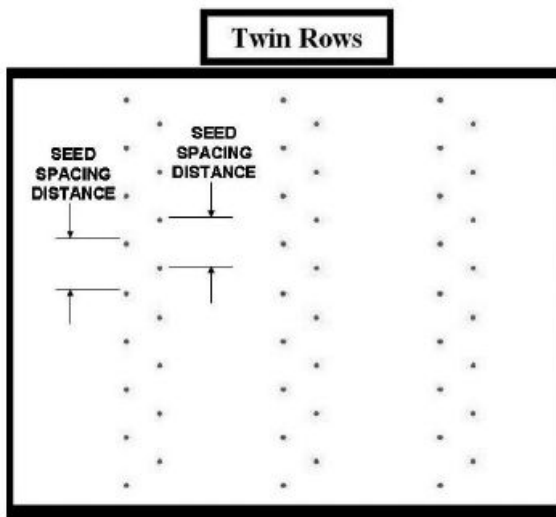

ROW SPACING  
Twin Rows

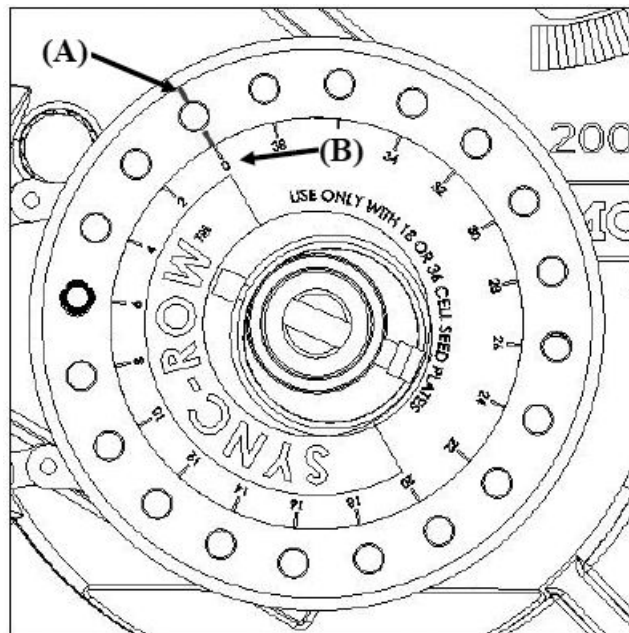

Adjustable Sprocket

APY09734 —UN—20MAR19

APY09735 —UN—20MAR19

- B - Recall the chart number (Step 3) for this Twin-Row pair. Turn the Sync Row plate until the chart number is inline with the pin (A) and then engage the pin with that hole.
- Reach through the viewing window on the opposite side of the meter and turn the seed plate backwards by hand until the lynch pin holes line up. Re-install the lynch pin. The Twin-Row pair should now be set for staggered seed placement.
- Repeat Steps 5A through 5D for each Twin-Row unit pair.

*NOTE: Monosem Inc. is not responsible for failure to place seeds in a staggered pattern. All settings and recommended adjustments are theoretical and subject to variations in soil type, mechanical drive wheel slip, operator error, etc.*

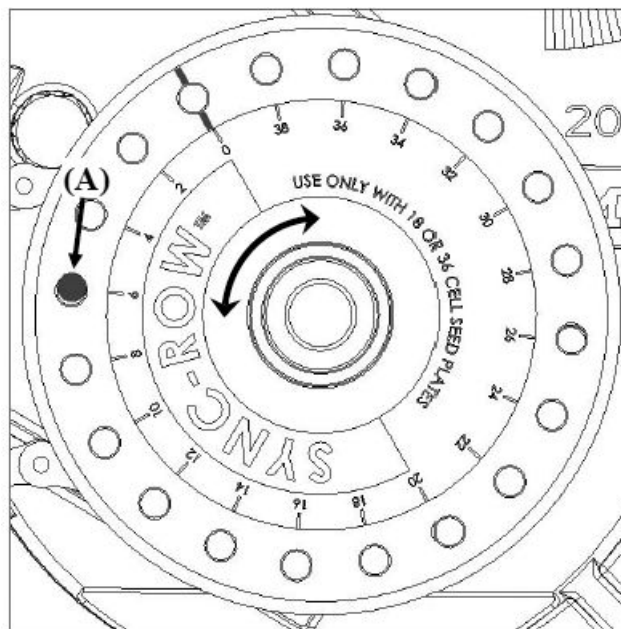

Adjustable Sprocket

**CALIBRATE ADJUSTABLE SPROCKET**

(In reference to Step 4)

*NOTE: READ ALL INSTRUCTIONS COMPLETELY BEFORE BEGINNING PROCEDURE.*

Monosem is providing an instruction supplement on how to calibrate (set zero) the Sync-Row timing system installed on Monosem twin-row planters. For most accurate operation, the Sync-Row system should be calibrated (set zero) at the start of each planting season and after replacement of any parts in the Sync-Row system. During this process it will be necessary to work between the planter units. Proper support for the planter will be necessary if not placed completely on the ground. Please have adequate equipment and personnel available to safely facilitate these actions.

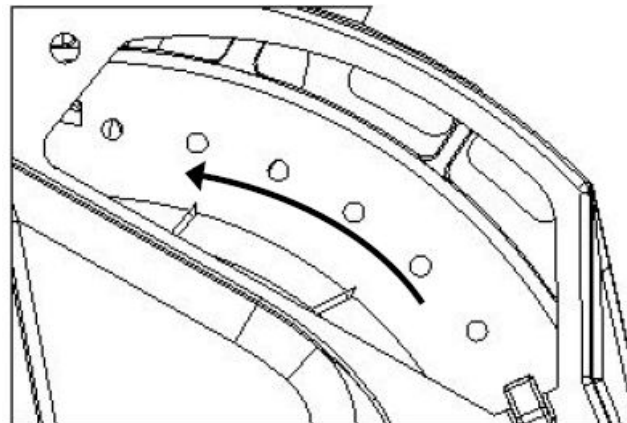

Twin Row Pair

1. Tools Needed:
  - 7/8 inch open-end wrench
  - Black magic marker
  - Solvent (carb cleaner)
  - Shop rag
  - Tools to remove drive chain connector link
2. Planter Preparation:
  - a. Position planter, unfolded, in a flat, open area and lower to field position.
  - b. Clear all seed meters of seed and debris.
  - c. If necessary, raise planter to place seed meters at a more comfortable working position.

*NOTE: Properly support planter at this new position so it is safe to work under and between the row units.*

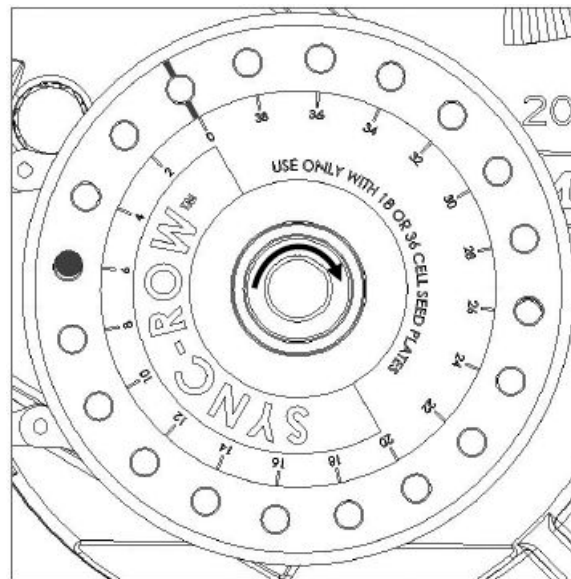

Twin Row Pair

- d. Install the appropriate 18, 36, or 72 cell seed plates.
- e. On ground drive planters, remove the drive chain from the transmissions.
- f. On hydraulic drive planters, remove the drive chain between the hydraulic motors and the lower hex shaft.

Continued on next page

HS35416,0000D67 -19-25JUN19-3/6

APY09736 —UN—20MAR19

APY09737 —UN—20MAR19

APY09738 —UN—20MAR19

3. **Calibrate (Zero) the Meters:**

- a. Set Sync-Row dial to original zero (Marked by a black line under the magnetic decal).
- b. Raise control windows on front and back meters on first set of twin rows. .
- c. Place a 7/8" wrench on the hex shaft and turn clockwise (top of shaft moves toward the tractor) at the same time place a thumb on the seed disc of the front meter through the control window and apply enough pressure to keep the disc from freewheeling forward and to take up any slack in the meter drive chain. See Figure 1.



Figure 1

APY09739 —UN—13MAR19

d. Turn the shaft until the tip of the seed scraper is flush with the back of the cell in the seed plate. See Figure 2.  
 e. Remove the wrench from the hex shaft and finger from the front plate. The seed plate may rotate forward slightly.

f. Move to the rear meter and apply approximately the same amount of pressure with your thumb to the seed plate in a counter-clockwise direction.

g. Observe the location of the seed cell nearest the tip of the scraper, See Figure 3.

If the back edge of the seed cell hole is within  $\pm 1/16$ " from the tip of the scraper then the meter is still calibrated (zeroed) and does not need adjustment. Skip to step 4

If the back edge of the seed cell hole is more than  $\pm 1/16$ " from the tip of the scraper then the Sync-Row dial setting will need to be adjusted.

h. Adjust the Sync-Row dial setting  
 Remove the lynch pin

Pull selector dial forward off pin and rotate clockwise to next hole (2, 4, 6, etc.) and slide back onto pin.

Reach through the control window and turn the seed disc counter-clockwise until the lynch pin holes line up. Reinstall lynch pin

Apply the same counter-clockwise pressure to the seed disc and recheck seed cell hole location.

i. Repeat step h and continue indexing the selector dial clockwise until the back edge of the seed cell hole is within  $\pm 1/16$ " from the tip of the scraper. This will be the new "0" dial setting.

j. Remove magnetic ring from dial.

k. Use solvent and a rag to remove previous zero mark.

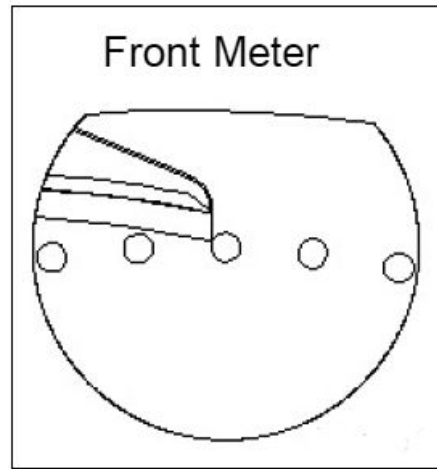

Figure 2

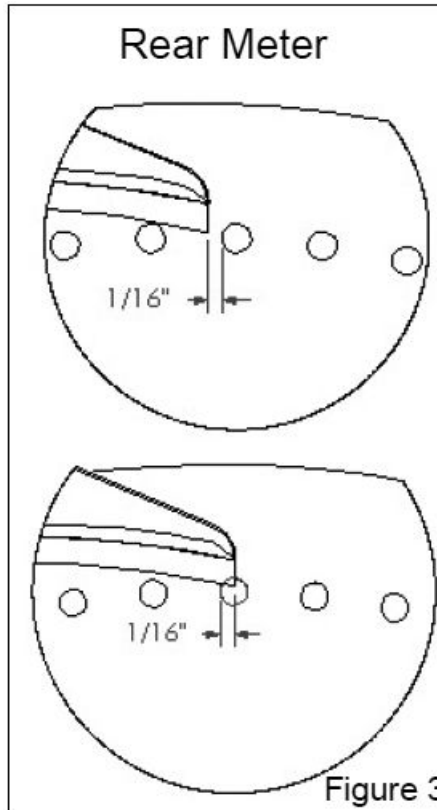

Figure 3

APY09740 —UN—13MAR19

APY09741 —UN—13MAR19



- l. Using a black marker, place a new zero mark on the disc has the peg in it. (See Figure 4)
  - m. Reinstall the magnetic ring with the "0" aligned with the zero mark and peg. (See Figure 5)
  - n. Repeat steps c thru m for each remaining set of twin
4. Reinstall drive chains and any additional parts removed

The Twin-Row meters are now calibrated (zeroed) and ready for adjustment based on your desired seeding population. Please reference appropriate Sync-Row chart for proper settings.

(This Chart is for an 18 cell plate)	Twin Row Spacing (Inches)	30
Seed Population (Seeds/Acre)	Seed Distance (Inches)	Chart Number
50000	8 3/8	8
49000	8 1/2	8
48000	8 3/4	10
47000	8 7/8	10
46000	9 1/8	10
45000	9 1/4	12
44000	9 1/2	12
43000	9 3/4	14
42000	10	14
41000	10 1/4	16
40000	10 1/2	16
39000	10 3/4	16
38000	11	18
37000	11 1/4	18
36000	11 1/2	0
35000	12	0
34000	12 1/4	2
33000	12 3/4	2
32000	13	2
31000	13 1/2	4
30000	14	4
29000	14 1/2	6
28000	15	6
27000	15 1/2	8
26000	16	8
25000	16 3/4	8
24000	17 1/2	10
23000	18 1/4	10
22000	19	12
21000	20	12
20000	21	14
19000	22	14
18000	23 1/4	14
17000	24 1/2	16
16000	26 1/4	16
15000	28	18

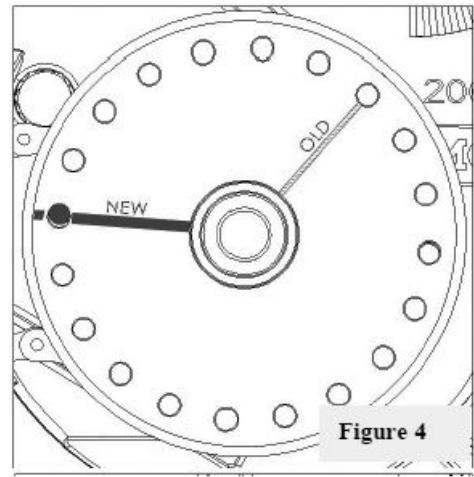

Figure 4

Figure 4

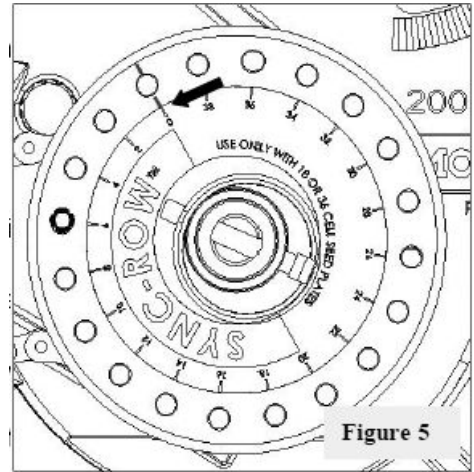

Figure 5

Figure 5

APY09742—UN—20MAR19

APY09758—UN—22MAR19

**OPTIONS**

(This Chart is for an 18 cell plate)	Twin Row Spacing (Inches)	36
Seed Population (Seeds / Acre)	Seed Distance (Inches)	Chart Number
50000	7	0
49000	7.125	0
48000	7.25	2
47000	7.375	2
46000	7.625	4
45000	7.75	4
44000	7.875	6
43000	8.125	6
42000	8.25	8
41000	8.5	8
40000	8.75	10
39000	8.875	10
38000	9.125	12
37000	9.375	12
36000	9.625	14
35000	10	14
34000	10.25	16
33000	10.5	16
32000	11	18
31000	11.25	18
30000	11.5	0
29000	12	0
28000	12.5	2
27000	13	2
26000	13.5	4
25000	14	4
24000	14 1/2	6
23000	15 1/4	6
22000	15 3/4	8
21000	16 1/2	8
20000	17 1/2	10
19000	18 1/4	10
18000	19 1/4	12
17000	20 1/2	12
16000	21 3/4	14
15000	23 1/4	14

(This Chart is for an 18 cell plate)	Twin Row Spacing (Inches)	38
Seed Population (Seeds / Acre)	Seed Distance (Inches)	Chart Number
50000	6.625	16
49000	6.75	18
48000	6.875	18
47000	7	0
46000	7.125	0
45000	7.375	2
44000	7.5	2
43000	7.75	4
42000	7.75	4
41000	8	6
40000	8.25	6
39000	8.5	8
38000	8.75	10
37000	9	10
36000	9.25	12
35000	9.5	12
34000	9.75	14
33000	10	14
32000	10.25	16
31000	10.75	16
30000	11	18
29000	11.5	18
28000	11.75	0
27000	12.25	0
26000	12.75	2
25000	13.25	4
24000	13 3/4	4
23000	14 1/4	6
22000	15	6
21000	15 3/4	8
20000	16 1/2	8
19000	17 1/2	10
18000	18 1/4	10
17000	19 1/2	12
16000	20 3/4	12
15000	22	14

OPTIONS

(This Chart is for an 18 cell plate)	Twin Row Spacing (Inches)	40
Seed Population (Seeds / Acre)	Seed Distance (Inches)	Chart Number
50000	6.25	14
49000	6.375	14
48000	6.5	16
47000	6.625	16
46000	6.875	18
45000	7	0
44000	7.125	0
43000	7.25	2
42000	7.5	2
41000	7.75	4
40000	7.75	4
39000	8	6
38000	8.25	6
37000	8.5	8
36000	8.75	10
35000	9	10
34000	9.25	12
33000	9.5	12
32000	9.75	14
31000	10	14
30000	10.5	16
29000	10.75	18
28000	11.25	18
27000	11.5	0
26000	12	0
25000	12.5	2
24000	13	2
23000	13 3/4	4
22000	14 1/4	6
21000	15	6
20000	15 3/4	8
19000	16 1/2	8
18000	17 1/2	10
17000	18 1/2	10
16000	19 1/2	12
15000	21	14

HS35416,0000D67 -19-25JUN19-8/6

## Central Seed System

### Recommended Settings and Procedures

**Use of seed lubricant is required for all seeds for proper delivery to the vacuum seed meters.** Talc is the only lubricant recommended for use with the system. Mix talc thoroughly with seed to ensure even coating of all seed. **Do not use hands to mix talc. Use proper respiratory protection when handling talc.**

### Warning

**WARNING** Agricultural chemicals can be dangerous. Improper use can result in injury to persons, animals, and soil. Handle with care and follow instructions of the chemical manufacturer.

Follow chemical manufacturer's precautions and recommendations when handling parts coated with



seed treatments. Use proper skin, eye, and respiratory protection. **Do not attempt to pressurize the tank with the lid removed.**

T81389 —UN—28JUN13

HS35416,0000D68 -19-25JUN19-1/2

### Settings

Mix talc as recommended:

**For season start-up:** Without seed in the tank, add 10 cups of talc per tank, spread it across the bottom of the tank, seal the tank, and turn on blower fan to coat the inside of the tank and delivery hoses.

**First tank with seed:** 1 cup talc per 2 bu. of seed

**Regular use:** Sprinkle talc as seed is added to the tank in the following rates:

Corn, soybeans, cotton: 1 cup talc per 3 bushels of seed (1 cup per 3 units seed corn)

Milo, rice: 1 cup talc per 2 bushels of seed

**Excessive humidity, large seed, or heavy seed treatment:** Double the regular usage rate. Adjust the rate of talc as needed for varying conditions. Level the hopper with a stiff bristled broom.

### Setting Tank Pressure with Blower Fan

The central seed tanks must be pressurized to the correct pressure settings for the system to work correctly. To adjust tank pressure, adjust the hydraulic flow from the tractor remote going to the hydraulic blower fan. Usually this can be done from the tractor cab.

A hydraulic poppet valve is included in the system to cut hydraulic flow to the blower when the planter is raised. The valve is triggered by an implement lift switch. The same switch will control the tank agitator motors, on or off.



An over-running valve is included in the hydraulic system to prevent damage to the blower fan or hydraulics system when the hydraulic flow to the blower fan hydraulic is shut off.

APY09743 —UN—13MAR19

HS35416,0000D68 -19-25JUN19-2/2

## Setting Tank Pressure with Blower Eliminator

The central seed tanks must be pressurized to the correct pressure settings for the system to work correctly. To adjust tank pressure, adjust the hydraulic flow from the tractor remote going to the hydraulic blower fan. Usually this can be done from the tractor cab.

A hydraulic poppet valve is included in the system to cut hydraulic flow to the blower when the planter is raised. The valve is triggered by an implement lift switch. The same switch will control the tank agitator motors, on or off.

An over-running valve is included in the hydraulic system to prevent damage to the blower fan or hydraulics system when the hydraulic flow to the blower fan hydraulic is shut off.

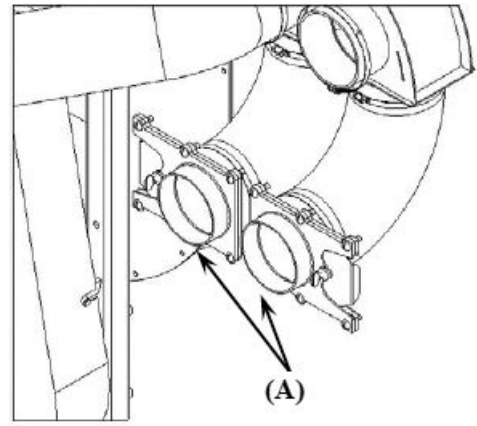

A—Blast Gates

### Setting Tank Pressure with Blower Eliminator

The Blower Eliminator takes air from the vacuum fan and directs it to the CSS tank to pressurize it. Follow these steps to set the vacuum and tank pressure. Note: Be sure the hydraulic system is warmed up before setting vacuum and pressure levels. Settings will drop if set while oil is below operating temperature.

1. With the Blast Gates (A) half open, lower the planter to the plant position and start the vacuum fans. This will activate the tank agitator. Ensure at least 20" of vacuum to supply enough air to transfer seed to the hoppers. Seed is needed in the meters so the plates can be filled with seed. (Note: vacuum levels will be higher when seed plates have seed on them).
2. Once enough seed has been transferred to the hoppers raise the planter so the agitator stops.
3. Turn the seed shafts to fill the seed plates.
4. Set the vacuum to the desired level.
5. Adjust Blast Gates (A) to achieve desired tank pressure.

6. Repeat Step 4 and Step 5 until desired setting are achieved.

**IMPORTANT: Make sure the case drain line for the hydraulic fan motor is connected to a zero-pressure drain port on the tractor.**

#### Recommended Pressure Settings:

Corn and Cotton: 6-12osi (oz./sq. in.)

Soybeans: 6-12 osi

Milo and Rice: 6-10 osi

Edible Beans: 8-15 osi

Tank agitator should run with the planter lowered in the field position. If lowered with tank full of seed for extended periods of time, turn off tractor key or unplug agitator.

HS35416,0000D69 -19-25JUN19-1/1

APY09744 —UN—20MAR19

## Microsem Microgranular Insecticide System

### Standard Microsem System

The Microsem system meters microgranular products such as insecticide and herbicide with precision. The system is ground driven and has a positive displacement. The output is set by means of a transmission that is unaffected by a change in planting speed. The Microsem system is mounted to the tool-bar frame with support brackets to reduce weight on the planter unit. The Microsem system

with auger is equipped with a telescoping outlet, and its output starts from a minimum of 2-3 lbs/acre.

Each Microsem hopper has a 33 lb. capacity and can be used with a double outlet for two row units or with a single outlet for one row unit.

The drive sprocket is mounted on the upper hex shaft. The hoses direct the granular product directly between the disc openers via drop tubes, or behind the disc openers via a spreader tube.

HS35416,0000D6A -19-25JUN19-1/1

**7085.SU**

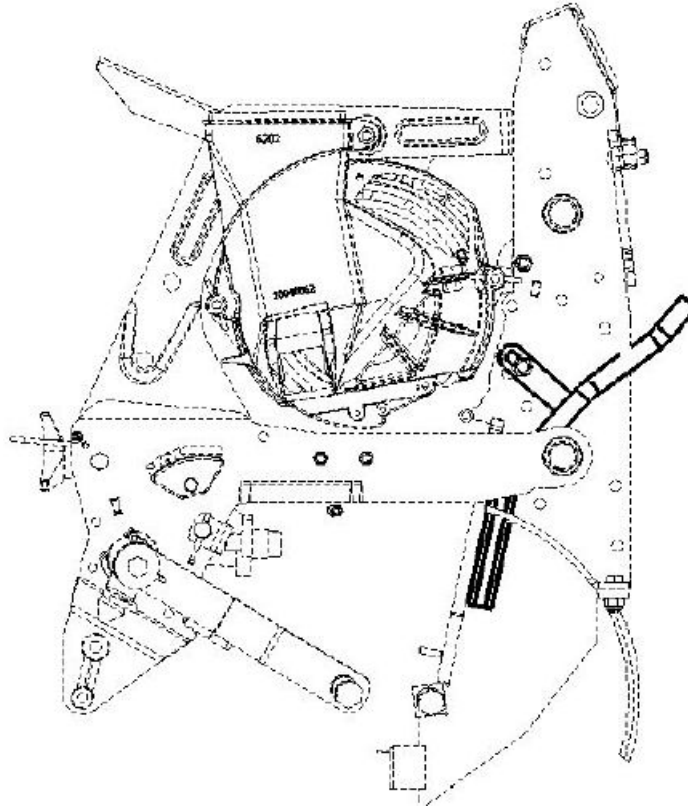

7085.SU

Mounts on the right hand side of the unit, with the same bolts that attach the disc scraper. It deposits material down in the seed trench in front of the seed tube. (Requires the edge above the double disc to be notched out).

HS35416,0000D6B -19-25JUN19-1/1

APY09746—UN—13MAR19

**Insecticide Drop Tube**

**7085.DA**

Mounts on the right hand side of the unit, with the same bolts that attach the disc scraper. It deposits material down in the seed trench behind the seed tube. The top of the tube points straight up.

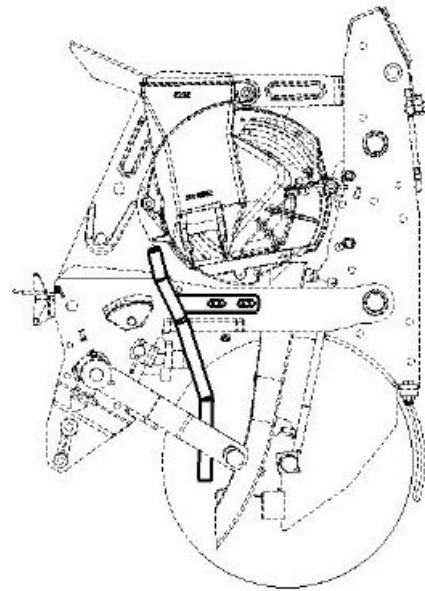

7085.DA

Continued on next page

HS35416,0000D6C -19-25JUN19-1/2

APY09745—UN—13MAR19

**7085.GA**

Mounts on the left hand side of the unit, with the same bolts that attach the disc scraper. It deposits material down in the seed trench behind the seed tube. The top of the tube points straight up.

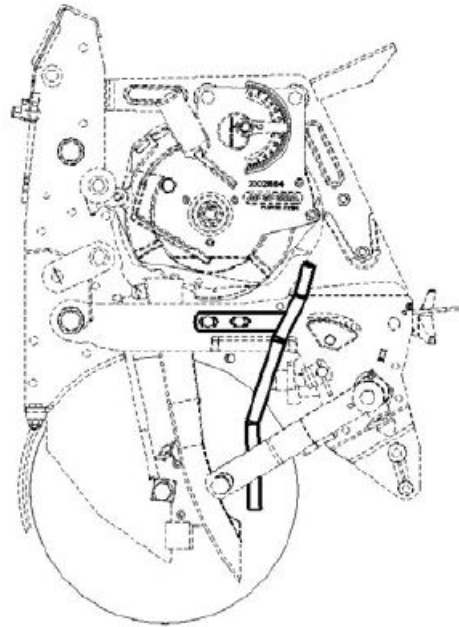

7085.GA

HS35416,0000D6C -19-25JUN19-2/2

APY09747 —UN—13MAR19

**Setting The Output**

The output is a function of the number of rotations of the spindle of the metering boxes, which is set primarily with the double sprocket (1) and the interchangeable sprockets (2). The chart provided will assist with the setting and also indicates the sprockets to be used for the principle commercial products. The furnished information is a recommendation only.

*NOTE: Avoid moisture contamination. Moisture in the product will cause hardening and could cause chain breakage. To avoid this problem, empty hoppers and store in a dry place.*

*NOTE: This unit should be used only with micro-granules and not with powders or granulates. It is possible to meter large granules provided the inside auger is changed for a special one.*

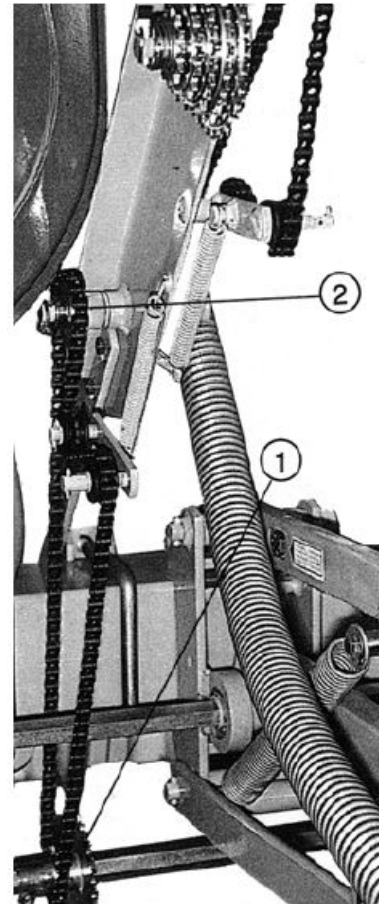

1— Double Sprocket

2— Interchangeable Sprocket

Continued on next page

HS35416,0000D6D -19-25JUN19-1/2

APY09748 —UN—13MAR19

**WARNING**

**Agricultural** chemicals can be dangerous. Improper use can result in injury to persons, animals and soil. Handle with care and follow instructions of the chemical manufacturer.

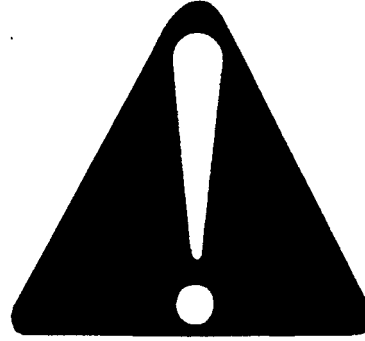

T81389 —UN—28JUN13

HS35416,0000D6D -19-25JUN19-2/2

**How To Test for Insecticide Rates**

Measure out a distance of 328 feet (100m).

Set the sprocket combination to: A=12, B=30, C=12.  
(This ratio = 0.24 or the number of Microsem shaft rotations for 1 drive wheel rotation.)

Remove the hoses from a 2 outlet hopper, placing a bag or other container to catch the product. Put the product into the Microsem hopper. Engage the Microsem and drive forward the pre-measured distance. Weigh the amount of product caught in the container and convert to grams.

Ounces x 31.103481 = grams  
Inches x 2.54 = cm

Use the following formula:

**Output = (10 \* quantity weighted (g) )/ (Inter-rows (cm) x 2)**

**Example:**

Inter-rows = 60 cm (23.63")

Quantity weighed = 60 grams (1.929 oz)

If 8 kg/ha or 8 lb/acre is required, choose the ratio  
 $8/5 * 0.24 = 0.384$

**A= 12, B= 18, C= 12**

If 11 kg/ha or 11 lb/acre is required, choose the ratio  
 $11/5 * 0.24 = 0.528$

**A= 12, B= 22, C= 20**

Output=  $(10*60)/(60 * 2) = 5$  kg/ha or **5 lb/acre**

From the following chart, find the closest sprocket combination to achieve appropriate lbs/acre.

*NOTE: Because of the large variety of insecticides and its density and irregularity of granulars, it is impossible to provide an exact chart. This is a close approximation only.*

HS35416,0000D6E -19-25JUN19-1/1



**Possible Sprocket Combinations**

Possible Sprocket Combinations			Ratios Obtained	
A	B	C		
12	35	12	-----0.21	Less Product
12	32	12	-----0.22	
12	<b>30</b>	12	-----0.24	
12	<b>25</b>	12	-----0.29	
12	<b>22</b>	12	-----0.33	
12	20	12	-----0.36	
12	<b>18</b>	12	-----0.4	
12	16	12	-----0.45	
12	<b>15</b>	12	-----0.48 or	
12	25	20	-----0.48	
12	23	20	-----0.51	
12	<b>22</b>	20	-----0.54	
<i>NOTE: The bold sprocket numbers for the interchangeable B sprocket are standard.</i>				
12	21	20	-----0.57	The remaining sprockets for the interchangeable B sprocket are available on request. (13-14-16-23-26-35)
12	<b>12</b>	12	-----0.6	
12	24	12	-----0.63	
12	<b>18</b>	21	-----0.66	
25	<b>22</b>	12	-----0.68	
12	10	12	-----0.72	
25	20	12	-----0.75	
12	<b>15</b>	20	-----0.8	
25	<b>18</b>	12	-----0.83	
25	16	12	-----0.94	
25	<b>15</b>	12	-----1 or	
12	12	20	-----1	
25	<b>22</b>	20	-----1.13	
12	10	20	-----1.2	
25	<b>12</b>	12	-----1.25	
25	<b>18</b>	20	-----1.4	
25	10	12	-----1.5	
25	<b>15</b>	20	-----1.66	
25	<b>12</b>	20	-----2.08	
25	10	20	-----2.5	

HS35416,0000D6F -19-25JUN19-1/1

**Trouble Shooting**

**PROBLEM:**  
Variations between the outlets or metering boxes.

POSSIBLE CAUSE:

- There may be foreign material mixed with the product

- ATTENTION: there may be moisture in the product.
- The metering unit may have been assembled improperly.
- The outlet chute may be warped.
- The hose may be too long or bent, causing the hose to clog.

HS35416,0000D70 -19-25JUN19-1/1

### Microsem Setting Chart - Drive Sprockets To Be Used

These settings are theoretical and approximate. Actual output may vary. Other outputs can be obtained by using different sprocket arrangements of the Microsem drive, however travel speed variations will not affect the output.

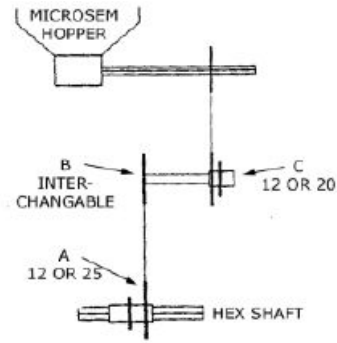

APY09755 —JUN—20MAR19

- A—Double sprocket on hex shaft - driven 1
- B—Interchangeable sprocket - driven 2
- C—12 or 20 tooth sprocket

#s per acre		A/ B/ C	A/ B/ C	A/ B/ C	A/ B/ C	A/ B/ C	A/ B/ C	A/ B/ C	A/ B/ C
<b>THIMET 20G</b>	22"	12/18/12	12/15/12	12/22/20	12/12/12	12/15/20	25/18/12		
	30"	12/22/20	12/18/20	25/20/12	25/18/12	25/15/12	25/22/20		
	36"	12/18/20	12/15/20	25/16/12	25/15/12	25/12/12			
	40"	25/22/12	25/18/12	25/15/12	25/22/20				
<b>#s per acre</b>		<b>3.26</b>	<b>3.92</b>	<b>4.40</b>	<b>4.89</b>	<b>6.00</b>	<b>6.80</b>	<b>7.50</b>	
<b>Ag Logic</b>	22"	12/18/12	12/22/20	25/22/12	25/18/12	25/15/12	25/22/20	25/12/12	
	30"	12/22/20	12/15/20	25/15/12	25/22/20	25/18/20	25/16/20	25/15/20	
	36"	12/18/20	25/16/12	25/22/20	25/18/20	25/15/20	25/14/20	25/12/20	
	40"	12/15/20	25/15/12	25/12/12	25/15/20	25/14/20	25/12/20		

HS35416,0000D71 -19-25JUN19-1/1

## Liquid Fertilizer

### 3 point Mounted Planters

#### Pump Mounting and Hose Arrangement

The squeeze pump is shipped with the discharge manifold in the rearward or non-operating position. Before operating or mounting the pump, position the discharge manifold in the forward or operating position and secure by tightening the wing nuts.

The pump should always be mounted even with or lower than the fertilizer tank for accurate metering. The rate of liquid fertilizer application is determined by the combination of sprockets on the squeeze pump and the drive shafts (see chart). When changing the sprocket combinations, check that the sprockets are in alignment, that the sprocket retaining collars are tight and that the chain tension is restored.

The shut-off valves should be closed to shut off the flow when the pump is not in use, either overnight, or for an extended amount of time. Also close the valves when servicing either the pump or the hoses.

To prolong the life of the hoses, the discharge manifold must be repositioned to the rearward position when not in use to prevent hose distortion.

The discharge pump must be in the forward position when the pump is in operation. To reposition the manifold, loosen the wing nuts and slide the manifold forward and sideways or rearward as required and retighten the nuts.

**⚠ CAUTION: Agricultural chemicals can be dangerous. Improper use can result in injury to persons, animals, and soil. Handle with care and follow instructions of the chemical manufacturer.**

**IMPORTANT: If the fertilizer is placed too close to the seed, it may cause germination or seedling damage especially if used in amounts in excess of the fertilizer manufacturer's recommendations. Consult with a fertilizer dealer or manufacturer for the correct amount and placement of fertilizer.**

#### Delivery Rate Chart

The following delivery rate chart provides an approximate application rate only. Actual delivery will vary with temperature and the type of fertilizer being used.

Chart is shown in gallons per acre. This chart is for a pump with a 1/2" hose. For settings with a 5/16" hose, cut gal/acre in half.

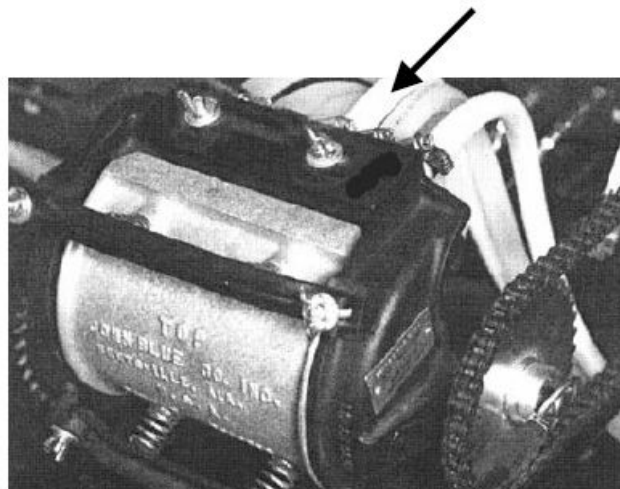

Discharge Manifold Rearward

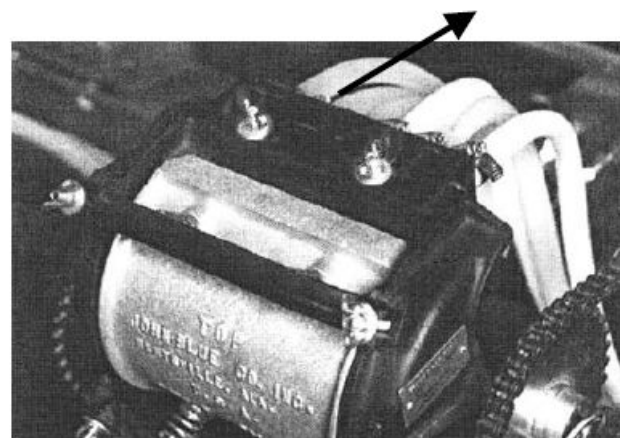

Discharge Manifold Forward

16 Tooth Driver Sprocket					
Sprocket Part #	Driven	40"	38"	36"	30"
L-1383	8	21.9	23.1	23.9	29
L-1384	9	19.1	20.4	21	25.3
L-1385	10	17.2	18.3	18.9	22.7
L-1386	15	11.4	12.1	12.5	15
L-1381	20	8.6	9.1	9.4	11.3
L-1387	22	7.7	8.2	8.5	10.2
L-1388	23	7.5	8	8.3	9.6
L-1389	26	6.7	7.1	7.3	8.8
L-1390	30	5.8	6.2	6.4	7.7
L-1391	31	5.6	5.9	6.1	7.4
L-1392	32	5.5	5.8	6	7.3
		Gallons per Acre			

APY09749 —UN—13MART19

APY09750 —UN—13MART19

OPTIONS

30 Tooth Driver Sprocket					
Sprocket Part #	Driven	40"	38"	36"	30"
L-1383	8	40	43	44.5	53.3
L-1384	9	35.9	38.2	39.5	47.4
L-1385	10	32.2	34.3	39.5	42.6
L-1386	15	21.5	22.9	23.6	28.4
L-1381	20	16.1	17.1	17.7	21.3
L-1387	22	14.6	15.6	16.1	19.3
L-1388	23	14	14.9	15.4	18.4
L-1389	26	12.5	13.3	13.7	16.5
L-1390	30	10.7	11.4	11.8	14.2
L-1391	31	10.3	11	11.3	13.6
L-1392	32	10.1	10.7	11.1	13.3
		Gallons per Acre			

HS35416,0000D72 -19-25JUN19-2/2

### Optional Piston Pump

If the machine is equipped with the piston pump option, the rate of liquid fertilizer application is determined by the piston pump settings.

To adjust delivery rate, loosen the 3/8" lock nut that secured the arm with the pointer and rotate the scale flange until the pointer is over the desired scale setting. The adjustment wrench will facilitate rotation of the scale flange. Tighten the 3/8" lock nut being careful not to over tighten.

#### Cleaning

The tanks and all hoses are made of sturdy plastic and rubber to resist corrosion. However, the tanks, hoses and metering pump should be thoroughly cleaned with water at the end of the planting season or prior to an extended period of non-use. Do not allow fertilizer to crystallize due to cold temperature or evaporation.

On machines equipped with the piston pump, the strainer located between the piston pump and ball valve should be taken apart and cleaned daily. Remove the end cap to clean the screen.

#### Piston Pump Storage

KEEP AIR OUT OF THE PUMP! This is the only way to prevent corrosion. Even for short periods of storage,

#### Piston Pump Application Rates

Piston Pump Application Rates									
Pump Setting	2	3	4	5	6	7	8	9	10
4-row 30"	13	19	26	32	38	45	51	58	64
4-row 36"	11	16	21	27	32	37	43	48	54
4-row 38"	10	15	20	26	30	35	41	46	51
6-row 30"	9	13	17	21	25	30	35	39	43
6-row 36"	7	11	14	18	21	25	29	32	36
6-row 38"	7	10	13	17	20	24	27	31	34
8-row 30"	7	10	13	16	19	23	26	29	32
8-row 36"	5	8	11	13.5	16	19	21.5	24	27
8-row 38"	5	7	10	13	15	18	20	23	25
12-row 30"	4	6.5	8.5	11	13	15	17	19.5	21
12-row 36"	4	5.5	7	9	11	12.5	14.5	16	18
12-row 38"	3	5	6.5	8.5	10	12	13.5	15	17

The above chart is for planters equipped with ground drive wheels that have 7.60 x 15 tires, 26 tooth drive sprocket, and a 22 tooth driven. This chart is based on average wheel slippage and liquid viscosities. This chart is also based on standard pump sprockets of 30 tooth drive and 16 tooth driven. Other sprockets are available.

Measure and weigh one gallon of actual fertilizer solution to determine exact application rates. This chart was calculated based on a solution weighing 10 pounds per gallon.

**IMPORTANT: Fertilizer application rates can vary from the above chart. To prevent application**

**miscalculation, make field checks to be sure fertilizer is being applied to all rows at the desired rate.**

*NOTE: Flow to all rows should be checked periodically. If one or more lines are plugged, the desired rate will be delivered to the remaining rows keeping total application rate at desired rate.*

How to check the exact number of gallons fertilizer attachment will actually deliver on 30" row spacing, proceed as follows:

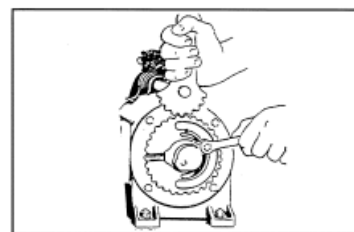

the entrance of air into the pump will cause **RAPID AND SEVERE CORROSION.**

#### Overnight Storage

Suspension Fertilizer must be flushed from the pump for ANY storage period.

#### Winter Storage

1. Flush pump thoroughly with 5 to 10 gallons of fresh water and circulate until all corrosive salts are dissolved in the pump.
2. With the pump set on 10, draw in a mixture of half diesel fuel and half 10 weight oil until the discharge is clean. Then plug inlet and outlet.

APY09751 —UN—13MAR19

## OPTIONS

1. Remove the hose from one of the fertilizer openers and insert it into a collection container that has been secured to the planter frame.
2. Engage the fertilizer attachment and drive forward for 174'.
3. Measure the fluid ounces caught in the container and multiply that amount by .78.
4. The result will be the gallons of fertilizer delivered per acre when planting in 30" rows. Rinse the collection container and repeat test on other rows if necessary.

To convert this delivery rate for wider rows, multiply by the following conversion factors:

- For 36" rows, multiply by .65 by result
- For 38" rows, multiply by .62 by result

### Trouble Shooting

PROBLEM:

#### Pump Hard or Impossible to Prime

Pump Hard or Impossible to Prime	
POSSIBLE CAUSE	SOLUTION
Valves fouled or in wrong place.	Inspect and clean valves
Air leak in suction line.	Repair leak
Pump is set too low.	Adjust pump setting
Packing washers are worn out.	Replace

### Low Metering

Low Metering	
POSSIBLE CAUSE	SOLUTION
Valves fouled or in wrong place.	Inspect and clean valves
Air leak in suction line	Repair leak
Pump is set too low.	Adjust pump setting
Broken valve spring	Replace

### Over Metering

Over Metering	
POSSIBLE CAUSE	SOLUTION
Improper rate setting	Adjust pump setting
Trash is under valves	Inspect and clean valves
Broken discharge valve spring	Replace

### Leaks Through when Stopped

Leaks Through when Stopped	
POSSIBLE CAUSE	SOLUTION
Trash is under valves	Inspect and clean valves
Broken discharge valve spring	Replace

### Fertilizer Solution leaking under stuffing box

Fertilizer Solution leaking under stuffing box	
POSSIBLE CAUSE	SOLUTION
Packing washers are worn out	Replace

### Pump is using excessive Oil

Pump is using excessive Oil	
POSSIBLE CAUSE	SOLUTION
Oil seals or O-ring worn and leaking	Replace

### Pump operates noisily

Pump operates noisily	
POSSIBLE CAUSE	SOLUTION
Crankcase components worn excessively	Inspect and replace if necessary

HS35416,0000D73 -19-25JUN19-2/2

## Dry Fertilizer

The Monosem dry fertilizer system is precisely metered by use of an auger. The standard output is adjustable from 80-350 lbs/acre and up to 600 lbs/acre using a high output auger. A non-corrosive plastic hopper with drain plug has a capacity of from 2-row 500 lbs to 12-row 2900 lbs with single, double or triple outlet hoppers. A flexible knife opener or a double disc opener applies fertilizer from a minimum of 2" to the side of the seed line.

### Assembly and Adjustment

The supports (1) of the fertilizer can be attached at two different widths on the hoppers, and can be easily attached to available spots on the bar. See diagram as shown.

The drive is normally mounted in the center of the machine, as close as possible to the left side of the gearbox. For narrow inter-row spacing this drive can be placed on the outside of the tool-bar frame. In that case, an optional bearing (#4515) can be used.

It is possible (but not necessary) to counter clamp the fertilizer opener clamps to the planting units. The two inner rows cannot always be mounted in this manner because of the hitch brackets. As half of the fertilizer knives are offset to the left and the other half are offset to the right, they can be adjusted as needed.

*NOTE: When using double disc openers the wheels of the tractor must be perfectly centered on the inter-rows or the spring leaves will come in contact with the tires during lifting.*

*NOTE: With row spacing of less than 32" (80 cm) the double disc openers are not compatible with the standard semi-automatic hitch. Semi-automatic hitch with short shaft and pin are required, or manual hitch with pins.*

*NOTE: If the connector tubes between the hoppers are too long, they can be cut to size.*

As an option, a 2-row hopper can feed 3 or 4 outlets, and a 3-row hopper can feed 4, 5, or 6 outlets. The fertilizers are then delivered with a meter specially equipped and plugs to allow certain outlets to be blocked off as desired.

**The primary adjustment** is set by using the lower double sprocket. **The final adjustment** is made by using one

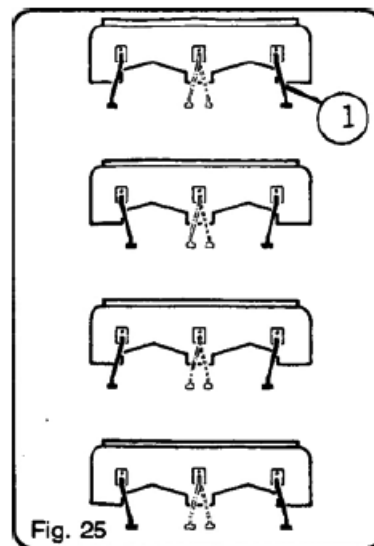

Fig. 25

of the sprockets of the upper sprocket cluster. Outputs can thus be obtained between approximately 80 to 350 lbs/acre (80-350 kg/ha).

Different outputs can be obtained by replacing the standard auger painted blue, with a special (optional) high output auger painted red.

Because of the large variety of fertilizers and its density and irregularity of granules, it is impossible to furnish an exact setting chart. To make an initial setting, as a guide only, an output of 80 lbs/acre, approximately between 1.2 lbs for each 334 feet (600-650 grams every 100 meters) is obtained with many types of fertilizers using the small lower sprocket cluster and the big upper sprocket cluster.

The placement of the fertilizer should be between 2" and 4" (6 and 10 cm) on the side of the row. A closer placement than what is recommended may cause the plant to burn and curb its growth.

Use How to Test Fertilizer Rates to find correct sprocket setting for the desired fertilizer rate.

### Application Chart

Rates in lbs/ acre

Application Chart								
	22"		30"		36"		40"	
Output Type	Standard	High	Standard	High	Standard	High	Standard	High
Auger Color	Blue	Red	Blue	Red	Blue	Red	Blue	Red
Sprockets: A/ B								
12/ 35	92	217	68	160	57	133	51	120
13/ 35	101	238	74	175	62	146	56	131
12/ 30	110	258	81	190	67	158	60	142
13/ 30	116	272	85	200	71	166	64	150
12/ 22	145	340	106	250	88	208	79	187

Continued on next page

HS35416,0000D74 -19-25JUN19-1/3

APY09752 —UN—20MAR19

## OPTIONS

**Application Chart**

13/ 22	162	380	119	280	99	233	89	210
21/ 35	165	388	121	285	101	238	91	214
12/ 19	170	401	125	295	105	246	94	221
23/ 35	176	414	130	305	108	254	97	229
13/ 19	185	435	136	320	113	267	102	240
21/ 30	190	448	140	330	117	275	105	248
25/ 35	193	455	142	335	119	279	107	251
12/ 16	202	476	149	350	124	292	111	262
25/ 30	208	490	153	360	128	300	115	270
13/ 16	219	516	162	380	135	317	121	285
25/ 30	225	530	166	390	138	325	125	293
21/ 22	257	605	189	445	158	371	142	334
12/ 12	272	639	200	470	167	392	150	353
23/ 22	283	666	208	490	173	408	156	368
13/ 12	295	693	217	510	181	425	163	383
21/ 19	300	707	221	520	184	433	166	390
25/ 22	306	720	225	530	187	441	169	398
23/ 19	329	775	242	570	202	475	182	428
25/ 19	355	836	261	615	218	512	196	461
23/ 16	387	911	285	670	237	558	214	503
25/ 16	425	999	312	735	260	612	234	551
21/ 12	477	1122	351	825	292	687	263	619
23/ 12	520	1224	383	900	319	750	287	675
25/ 12	566	1333	417	980	347	816	312	735

### How to Test for Fertilizer Rates

To test the desired fertilizer to determine lbs/acre use the details below.

First measure out a distance of 328 feet in a row.

1. Remove one hose from a fertilizer hopper and attach a plastic bag, or other container, under the opening in the hopper.
2. Set the transmission to the following: Sprocket A: 21 Sprocket B: 30.
3. Engage the fertilizer attachment and drive forward the pre-measured distance of 328 feet (100 meters).
4. Weigh the amount of fertilizer caught in the container (in ounces).
5. Find the desired row spacing on the Calibration Chart below, locate the target ounces. Use the following formula to determine the Material Multiplier need to achieve the desired application rate.

**Target Ounces / Measured Ounces = Material Multiplier**  
**Material Multiplier x Application Chart Target Rate = Adjusted Target Rate**

Use sprocket setting from the Application Chart that is closest the Adjusted Target Rate found with the formula above.

**Example:** Row Spacing: 30", Sprocket setting **A 21 / B 30**  
 After driving 328 ft. the amount of fertilizer captured is measured and is found to be **29 oz.**

Using the formula and Calibration Chart

**34 oz / 29oz = 1.172**

The Material Multiplier is **1.172**.

The Target Application rate is **225 lbs/ac**

**225 lbs/ac x 1.172 = 263.7 lbs/ac**

The Adjusted Target Rate is **263.7 lbs/ac**

The closest rate from the Application Chart to the Adjusted Target Rate is **261 lbs/ac**

Use the corresponding sprocket setting for **261 lbs/ac** which is A 25 / B 19

The Actual Applied Rate will be closer the original target rate of **225 lbs./ac**

### Calibration Chart

*NOTE: Because all fertilizers do not have the same density and the granules can be irregular, it is impossible to furnish an exact setting chart.*

**Sprocket Setting: A 21 B 30**

Row Spacing	Ounces	
	Blue Auger	Red Auger
22"	25	59
30"	34	80
36"	41	96
40"	56	132

### HOW TO TEST FOR FERTILIZER RATES

Continued on next page

HS35416,0000D74 -19-25JUN19-2/3



**OPTIONS**

To test your desired fertilizer to determine lbs/acre use the chart below.

First measure out a distance of 328 feet in a row.

1. Remove one hose from a fertilizer hopper and attach a plastic bag, or other container, under the opening in the hopper.
2. Engage the fertilizer attachment and drive forward the pre-measured distance of 328 feet (100 meters).

3. Weigh the amount of fertilizer caught in the container (in ounces).
4. Find your row spacing on the below chart, locate the approximate ounces and follow the chart up to see

**CALIBRATION CHART**

*NOTE: Because all fertilizers do not have the same density and the granules can be irregular, it is impossible to furnish an exact setting chart.*

	lbs/ acre										
Row Spacing	80	90	100	120	130	140	170	190	200	210	220
22"	14	16	18	22	23	25	31	34	36	38	40
30"	20	22	24	29	32	34	42	47	49	51	54
36"	24	26	29	35	38	41	50	56	59	62	65
40"	32	36	40	48	52	56	68	76	80	84	88

HS35416.0000D74 -19-25JUN19-3/3

## Application Rates

### APPLICATION RATES

The following rates were calculated with a bulk density of 65 lbs/cubic foot.

This chart is for planters that are equipped with contact drive.

**IMPORTANT: Fertilizer application rates can vary from the weights calculated in this chart due to different brands, temperature, humidity, etc. These settings are theoretical and approximate. Actual output may vary.**

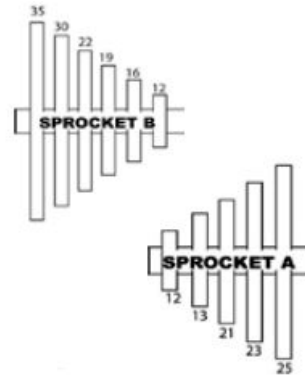

APY09756—UN—20MAR19

Application Rates in lbs/ acre

A/ B	22"		30"		36"		40"	
	Standard	High	Standard	High	Standard	High	Standard	High
Auger Color	Blue	Red	Blue	Red	Blue	Red	Blue	Red
12/ 35	92	217	68	160	57	133	51	120
13/ 35	101	238	74	175	62	146	56	131
12/ 30	110	258	81	190	67	158	60	142
13/ 30	116	272	85	200	71	166	64	150
12/ 22	145	340	106	250	88	208	79	187
13/ 22	162	380	119	280	99	233	89	210
21/ 35	165	388	121	285	101	238	91	214
12/ 19	170	401	125	295	105	246	94	221
23/ 35	176	414	130	305	108	254	97	229
13/ 19	185	435	136	320	113	267	102	240
21/ 30	190	448	140	330	117	275	105	248
25/ 35	193	455	142	335	119	279	107	251
12/ 16	202	476	149	350	124	292	111	262
25/ 30	208	490	153	360	128	300	115	270
13/ 16	219	516	162	380	135	317	121	285
25/ 30	225	530	166	390	138	325	125	293
21/ 22	257	605	189	445	158	371	142	334
12/ 12	272	639	200	470	167	392	150	353
23/ 22	283	666	208	490	173	408	156	368
13/ 12	295	693	217	510	181	425	163	383
21/ 19	300	707	221	520	184	433	166	390
25/ 22	306	720	225	530	187	441	169	398
23/ 19	329	775	242	570	202	475	182	428
25/ 19	355	836	261	615	218	512	196	461
23/ 16	387	911	285	670	237	558	214	503
25/ 16	425	999	312	735	260	612	234	551
21/ 12	477	1122	351	825	292	687	263	619
23/ 12	520	1224	383	900	319	750	287	675
25/ 12	566	1333	417	980	347	816	312	735

HS35416,0000D75 -19-25JUN19-1/1

## US Insecticide System

### Single Row Planters

#### Granular Application Rate

The US Insecticide System is mounted to the planter unit and has a hand clutch to engage or disengage the metering mechanism for easy removal of the hopper. Be sure no foreign objects get into the hopper when it is being filled with product. Keep hopper lids on when not being filled to prevent accumulation of dirt or moisture in the hoppers.

The delivery of granular chemicals can be affected by temperature, humidity, speed, ground conditions, flow ability of different materials or any obstruction in the meter.

*NOTE: Since the chemical meter is driven directly from the seed meter box, changing the seed population after calibrating will change the output of the chemical meter, even if ground speed remains constant.*

**⚠ CAUTION: Agricultural chemicals can be dangerous. Improper use can result in injury to persons, animals and soil. Handle with care and follow directions supplied by the chemical manufacturer.**

A field check is important to determine the correct application rates. The following method for calibrating is recommended:

1. Attach a plastic bag to each chemical meter outlet tube.
2. Lower the planter and drive 500 feet at the desired seeding population and speed.
3. Weigh (in ounces) the amount of chemical in one bag.
4. Multiply the number of ounces by the factor shown below for your row width.

Row Width	Factor
38"	1.7
36"	1.8
30"	2.2
22"	3

Example: Drive 500 feet. The row spacing is 30" and 4.5 ounces have been collected. Multiply 4.5 by the factor 2.2, found in the table above. This would indicate that the application rate is 9.9 lbs./acre.

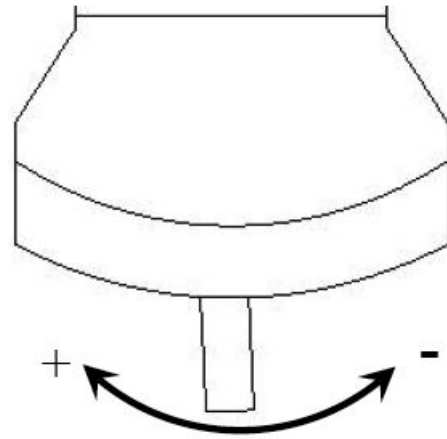

Adjust the metering gate accordingly until the desired rate is achieved. Zero for minimum output while 45 for maximum output.

It is suggested that after a desired rate is achieved through calibration, record the ground speed and transmission setting used for the calibration along with the chemical used for future reference.

*NOTE: It is important to check calibration of all rows.*

**⚠ CAUTION: Once the proper setting is achieved do not vary planting speed as this will affect the output.**

APY09753—UN—20MAR19

HS35416,0000D76 -19-25JUN19-1/1

Please record your planter identification information in box below for reference when ordering replacement parts for your Monosem planter.

Planter Type: \_\_\_\_\_

Serial Number: \_\_\_\_\_

Purchase Date: \_\_\_\_\_

Dealership: \_\_\_\_\_

\_\_\_\_\_

\_\_\_\_\_

**Suggestions For Successful Planting:**

1. Choose a reasonable working speed adapted to the field conditions and desired accuracy.
2. Check proper working of the seed metering, seed placement, spacing, and density when starting up and from time to time during planting.

## Monosem Inc. Product Warranty

A. **General Provisions.** Monosem Inc. ("Monosem") warrants each new product manufactured by Monosem ("Product(s)") to be free, under normal use and service, from defects in workmanship and materials for a period of one (1) year from the date of delivery (the "Term"). Monosem makes this warranty to original purchasers of Products from the original delivery date. This warranty is transferable, provided Monosem is notified of the ownership change and Monosem approves the warranty transfer.

B. **Warranty Claims.** During the Term, this warranty shall be fulfilled by repairing or replacing free of charge any Product that shows evidence of defect in workmanship or materials. To secure warranty service, the purchaser must 1) report the Product defect to an authorized Monosem dealer (a list of authorized Monosem dealers is available on Monosem's website, <http://monosem-inc.com/dealer-map/>), 2) present evidence of the warranty start date with valid proof of purchase, and 3) make the Product available to Monosem or an authorized Monosem dealer within a reasonable time. Parts and standard labor rates are covered by this warranty. Freight charges for defective Products are not covered by this warranty and are the responsibility of the purchaser.

C. **Exclusions.** Excluded from this warranty are: 1) Used Products; 2) repairs or replacements caused in whole or in part by parts or components not manufactured by or obtained from Monosem or by service not performed by Monosem authorized personnel or an authorized Monosem dealer; 3) any Product that has been altered or modified in ways not approved by Monosem, including but not limited to the use of unapproved attachments (including residue managers and coulters), accessories (including third-party drives and fertilizer pumps), carts or tanks; 4) depreciation or damage caused by normal wear and tear, lack of reasonable and proper maintenance, failure to follow operating instructions/recommendations, misuse, lack of proper protection during storage, vandalism, the elements, collision or accident; and 5) normal maintenance parts and/or service, including but not limited to calibrations, adjustments, inspections, and any consumables, including but not limited to tires, belts and rubber products and wear parts.

D. **No Other Express Warranty and no Implied Warranty, Representation or Condition.** No other express warranty is given and no affirmation of Monosem or an authorized Monosem dealer by words or actions, shall modify the terms or limitations of this warranty in any way. No retailer has any authority to make any warranty, representation, condition or promise on behalf of Monosem, or to modify the terms or limitations of this warranty in any way. Monosem shall not be liable for damages, including special, incidental or consequential damages or injuries (damage and repairs of equipment itself, loss of profits, rental or substitute equipment, loss of good will, etc.) arising out of or in connection with performance of the Product or its end use, and Monosem shall not be liable for any indirect, special, incidental, punitive or consequential damages arising out of or in connection with Monosem's failure to perform its obligations hereunder. Purchaser acknowledges that it is not relying on Monosem's skill or judgment to select Products for any purpose and that there are no warranties which are not contained in this warranty. In no event shall Monosem's tort, contract, or warranty liability exceed the purchase price of the Product.

TO THE EXTENT PERMITTED BY LAW, MONOSEM'S ENTIRE LIABILITY AND THE PURCHASER'S EXCLUSIVE REMEDY SHALL BE REPAIR OR REPLACEMENT OF PRODUCTS COVERED UNDER THIS WARRANTY. THIS WARRANTY IS IN LIEU OF ALL OTHER WARRANTIES, EXPRESS OR IMPLIED, INCLUDING, BUT NOT LIMITED TO THE IMPLIED WARRANTY OF MERCHANTABILITY OR FITNESS FOR A PARTICULAR PURPOSE.